

# OPERATOR'S MANUAL

FOR ST4949F, ST4949B, ST4949F, ST4933B

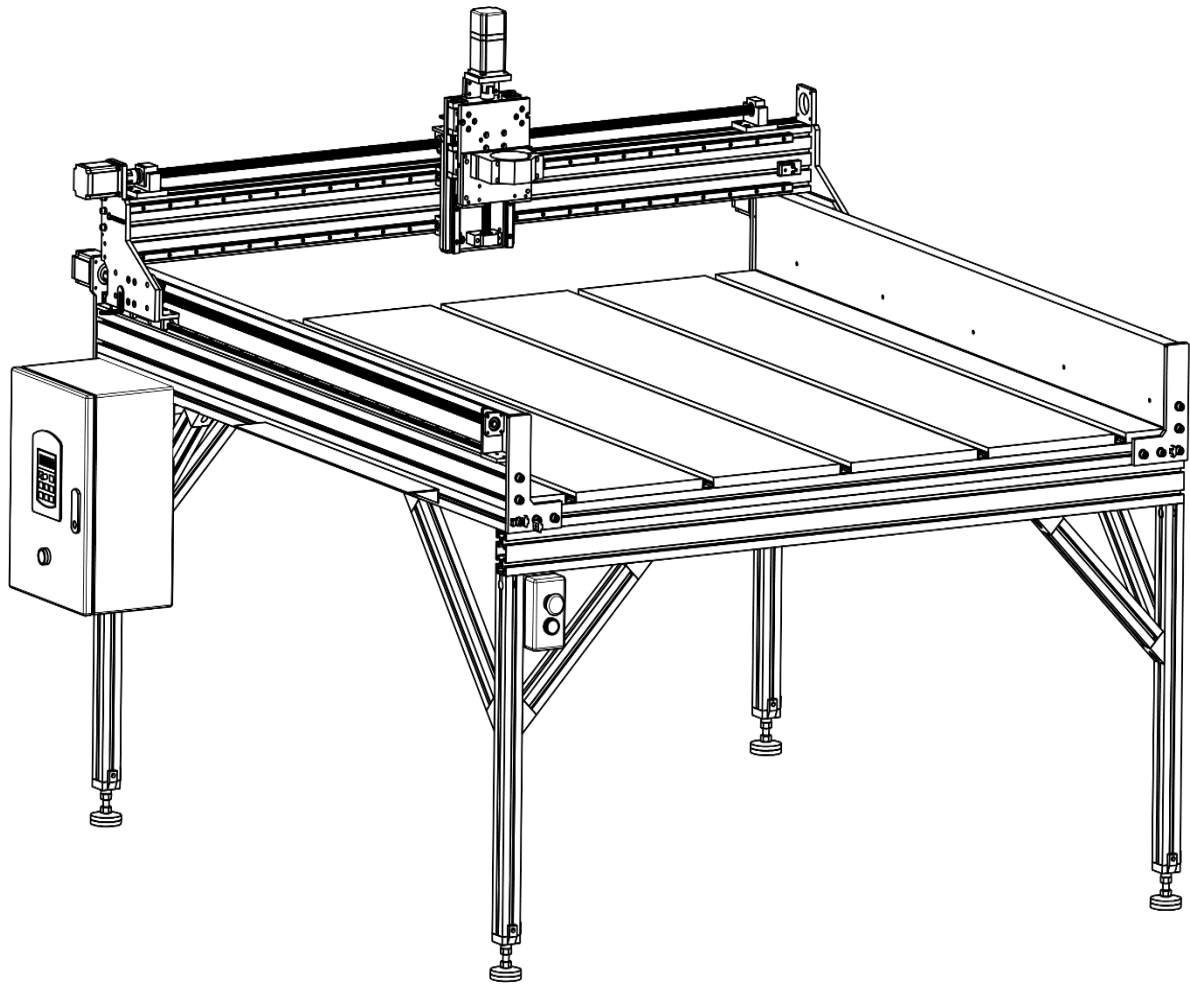

# CARVEMATE

## CNC ROUTER

( Version: 2.02 )

---

**⚠ WARNING:**

For your safety and to prevent machine damage, read and understand this manual before operating the product.

---

# Table of Contents

---

GETTING STARTED .....	1
1. Know Your CNC Router .....	1
2. Electrical .....	2
3. Dimensions .....	2
4. Cutting Capacity .....	2
5. Tools Needed .....	2
BASE .....	3
Parts List .....	3
1. Parts Included .....	3
2. Parts not Included .....	4
Assembly .....	5
1. Assembling Brackets .....	5
2. Y-Beams Orientation for Base .....	5
3. Assembling Front and Rear X-Cross Bars .....	6
4. Assembling Middle X-Cross Bars .....	6
5. Assembling Base Frame .....	7
6. Mounting Base Frame onto Bench Top .....	9
7. Installing Switch Box .....	9
8. Assembling Wasteboards onto Base Frame .....	10
STAND .....	11
Parts List .....	11
1. Parts Included .....	11
Assembly .....	13
1. Assembling Brackets .....	13
2. Attaching Cross Braces to Base .....	14
3. Assembling Reinforcement Beams .....	15
4. Attaching Reinforcement Beams to Base .....	16
5. Attaching Cross Braces and Legs to Stand .....	17
6. Assembling Leveling Feet .....	18
7. Positioning and Leveling Base and Stand .....	18
8. Installing Switch Box .....	18
XYZ UNIT .....	21
Parts List .....	21
1. Parts Included .....	21
Assembly .....	23
1. Assembling Y-Assemblies to Base .....	23

# Table of Contents

---

2. Assembling Brackets.....	24
3. Installing Joining Brackets to X-Assembly .....	25
4. Assembling X-Assembly to Y-Axis.....	26
5. Assembling Z-Assembly.....	29
Z-Assembly Squaring.....	30
1. Squaring Z-Assembly in X-Direction .....	30
2. Squaring Z-Assembly in Y-Direction .....	31
DRAG CHAIN.....	32
Parts List .....	32
1. Parts Included .....	32
Assembly.....	33
1. Assembling Drag Chain Mounts .....	33
2. Assembling Drag Chain Brackets .....	35
3. Assembling Y Drag Chains .....	36
4. Assembling X Drag Chains .....	37
ELECTRONICS.....	38
Parts List .....	38
1. Parts Included .....	38
Assembly.....	39
1. Installing Motors .....	39
2. Installing Limit Sensors .....	40
3. Installing VFD Enclosure.....	41
4. Installing Spindle.....	42
5. Cable Wiring.....	43
OPERATION .....	46
Coordinate System .....	46
Setup.....	47
1. Adjusting Limit Sensors to Set Machine Home Position.....	47
2. Mechanical Check.....	48
3. Controller.....	48
4. Connecting Controller to UGS.....	49
5. Configuring GRBL .....	50
6. Primary Software Operations .....	51
7. Limit Sensor Check .....	52
8. Motion and Speed Check.....	53
Adjustment .....	54

# Table of Contents

---

1. X-Axis Self-Squaring .....	54
2. Z-Axis Trimming .....	54
3. Pendant Box .....	55
4. Z Axis Probing .....	55
VFD and Spindle .....	57
TROUBLESHOOTING .....	58

# GETTING STARTED

## 1. KNOW YOUR CNC ROUTER

- ST4949B, ST4933B:  
Bench top models without floor stand.
- ST4949F, ST4933F:  
Full set models with floor stand.

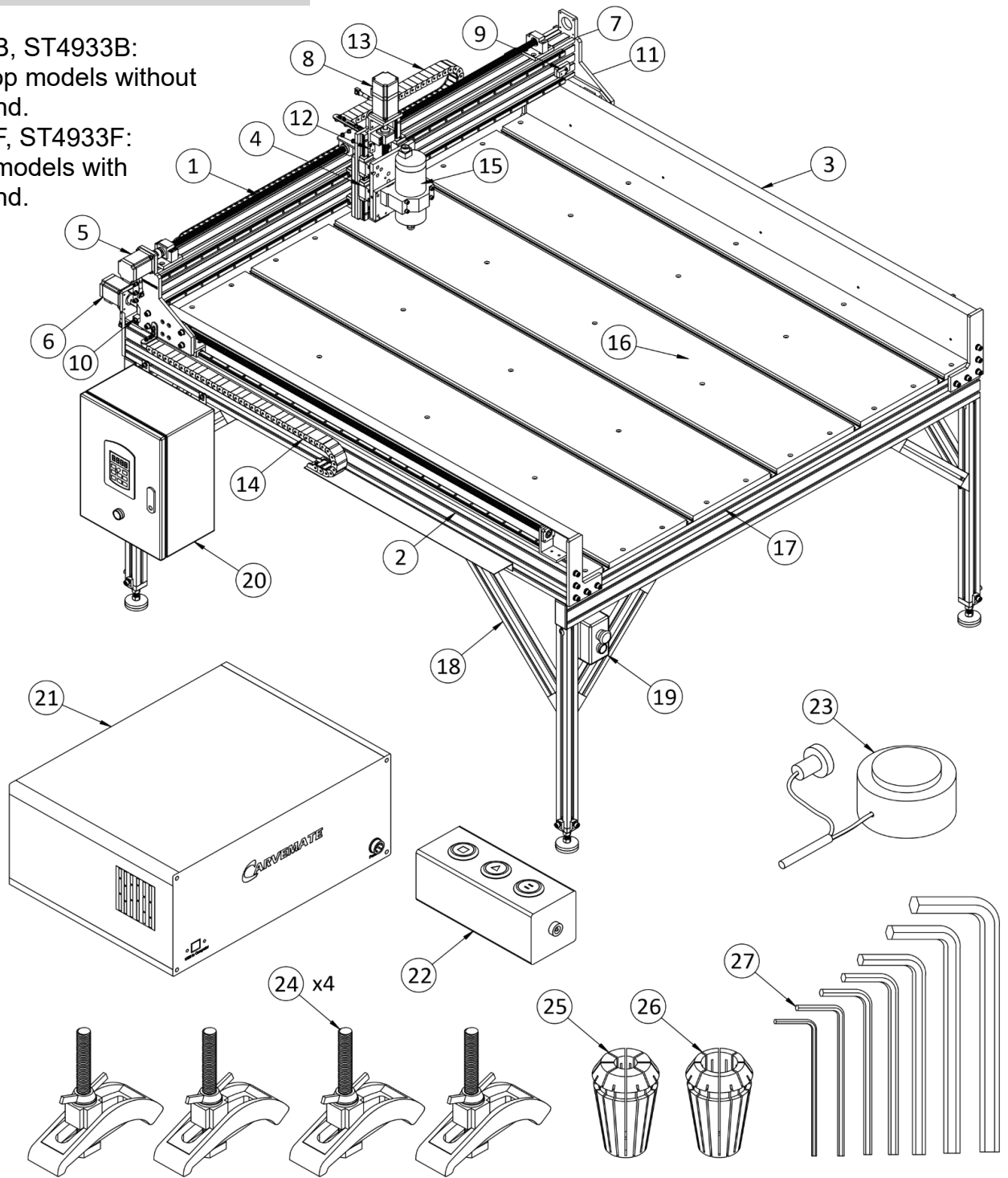

1: X-Assembly	2: Left Y-Assembly	3: Right Y-Assembly
4: Z-Assembly	5: X-Motor	6: Left Y-Motor
7: Right Y-Motor	8: Z-Motor	9: X-Limit Sensor
10: Left Y-Limit Sensor	11: Right Y-Limit Sensor	12: Z-Limit Sensor
13: X-Drag Chain	14: Y-Drag Chain	15: Spindle
16: Wasteboard	17: Base	18: Stand
19: Switch Box	20: VFD Enclosure	21: Controller
22: Pendant Box	23: Touch Probe	24: Hold-Down Clamps X4
25: Collets, 6 mm (with Spindle)	26: Collet, ¼ inch (with Spindle)	27: Allen Key Set

# GETTING STARTED

## 2. ELECTRICAL

- The machine's power supply must be **120V, 60 Hz AC**, connected to a **grounded**, 3-prong outlet. Ungrounded 2-prong outlets are prohibited.
- The VFD controller cannot operate on a GFCI (Ground Fault Circuit Interrupter) outlet. Only use non-GFCI outlets to power the VFD.
- A **15-amp** circuit is required for 1.5 kw spindle, and a **20-amp** circuit for 2.2 kw spindle.
- Use only 3-wire extension cord with 3-prong grounding plug and 3-pole receptacle.
- Select the proper extension cord gauge from the table below based on cord length.

**Wire Size (AWG) (When Using 120V Only)**

Ampere Rating	Cord Length			
	25' (7.6m)	50' (15m)	75' (22.8m)	100' (30.4m)
< 5	16	16	16	14
5 to 8	16	16	14	12
8 to 12	14	14	12	10
12 to 15	12	12	10	10
15 to 20	10	10	10	-

## 3. DIMENSIONS

Machine Dimensions:

- ST4949B: Width: 1624 mm (64 in), Depth: 1738 mm (68.4 in), Height: 632 mm (24.9 in)
- ST4933B: Width: 1624 mm (64 in), Depth: 1318 mm (51.9 in), Height: 632 mm (24.9 in)
- Stand height: 836 mm (33 in)
- Height including stand: 1468 mm (57.8 in)

## 4. CUTTING CAPACITY

- X: 1260 mm (49.6 in)
- Y: ST4949B, F: 1260 mm (49.6 in); ST4933B,F: 840 mm (33.07 in)
- Z: 132 mm (5.2 in) above 19 mm (0.75 in) wasteboard
- Z clearance: 130 mm (5.1 in)

## 5. TOOLS NEEDED

The following tools (not included) are needed for assembly and adjustment:

- Tape measure: metric
- Engineer's square: minimum: 250 mm (10 in)
- Rubber mallet
- Level: minimum length: 1200 mm (48 in), recommended length: 1700 mm (67 in)
- Phillips screwdriver
- Adjustable wrench or open-end wrench: 5.5 mm, 7 mm, 13mm

# BASE

# PARTS LIST

## 1. PARTS INCLUDED

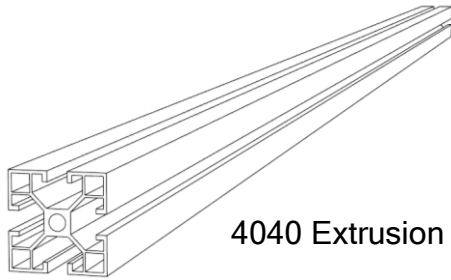

4040 Extrusion

	ST4949B, F		ST4933B, F	
<b>Model</b>	Y-Beam	X-Cross Bar	Y-Beam	X-Cross Bar
<b>Part Number</b>	AL114	AL12	AL113	AL12
<b>Length</b>	1630 mm	1444 mm	1210 mm	1444 mm
<b>Quantity</b>	2	5	2	5

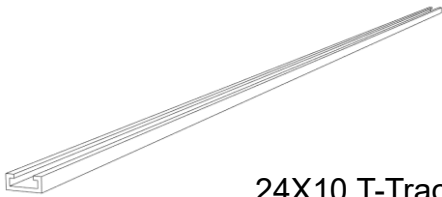

24X10 T-Track

	ST4949B, F	ST4933B, F
<b>Model</b>	T-Track	T-Track
<b>Part Number</b>	AL64	AL63
<b>Length</b>	1630 mm	1210 mm
<b>Quantity</b>	5	5

<b>Model</b>	Corner Bracket 4080	Angle Bracket	Corner Bracket 4040
<b>Part Number</b>	B1	B2	B3
<b>Quantity</b>	4	4	12

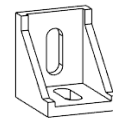
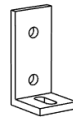
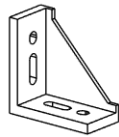

<b>Model</b>	40M5 T-Nut	40M6 T-nut	40M8 T-Nut	M8x25 Galvanized Hex Head Tapping Screw
<b>Part Number</b>	NS45	NS46	NS48	FG825C
<b>Quantity</b>	25	82	8	4 (not used for ST49xxF)

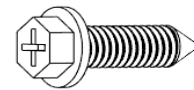
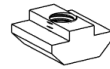
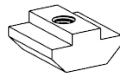
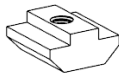

<b>Model</b>	M5x12 Galvanized Flat Head Screw	M6x25 Galvanized Flat Head Screw	M6x20 Galvanized Socket Head Screw with Lock Washer and Flat Washer
<b>Part Number</b>	FG512	FG625	FG620
<b>Quantity</b>	25	38	44 (40)

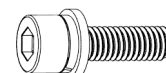

<b>Model</b>	M4x20 Galvanized Round Head Self- Tapping Screw
<b>Part Number</b>	FG420
<b>Quantity</b>	4



## 2. PARTS NOT INCLUDED

### WASTEBOARDS

- Disposable wasteboards, mounted on the base surface as the work surface, are not included. Use MDF boards with a minimum thickness of 19 mm (3/4 in).
- The wasteboards include six MDF boards with pre-drilled screw holes, separated by five aluminum T-tracks (AL6).
- Board widths, as shown in the diagram, may vary based on T-track (AL6) arrangement.
- The MDF board length (Imperial) should be 64-1/8 in for ST4949 or 47-5/8 in for ST4933.
- Total width of all six boards should not exceed 1320 mm (52 in).
- Additional T-tracks, screws (FG625), and spring nuts (NS6) can be purchased to enhance workpiece holding capacity. Wasteboards amount and dimensions need to be adjusted accordingly.
- If the hole spacing (397.5 mm or 292.5 mm) is changed, reposition the three middle X- cross bars (AL12) and re-drill the countersunk holes in the T-tracks, as the original pre-drilled holes will no longer align. (See Section 7 "ASSEMBLING BASE FRAME").

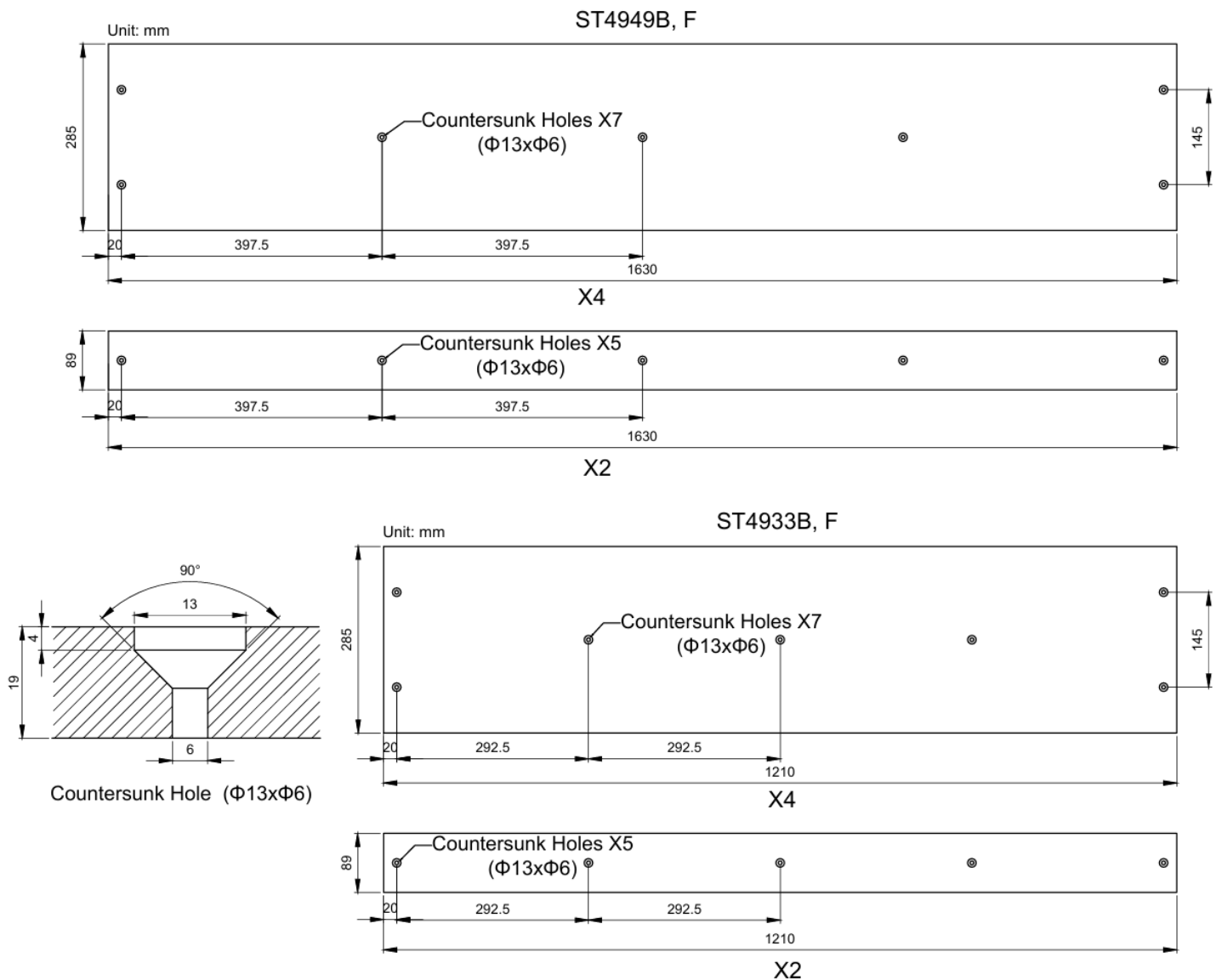

# BASE

# ASSEMBLY

## FOCUS ON:

- Checking for pre-inserted T-nuts before assembly.
- Aligning all top surfaces of the aluminum extrusions so they are flush.
- Aligning the side surfaces of the X-cross members flush with the ends of the Y-beams.
- Ensuring the base frame is assembled square and stable.

## 1. ASSEMBLING BRACKETS

### NOTE:

IF YOUR MODEL IS ST4949F OR ST4933F WITH A STAND, THE FOUR ANGLE BRACKETS ⑤ WILL BE ASSEMBLED LATER IN THE “STAND ASSEMBLY” SECTION.

- Assemble **Corner Brackets 4040** ①, **Corner Brackets 4080** ②, and **Angle Brackets** ⑤ (ST4949B, ST4933B only) using **40M6 T-Nuts** ③ and **M6x20 Galvanized Socket Head Screw Sets** ④ . Do not tighten the screws.

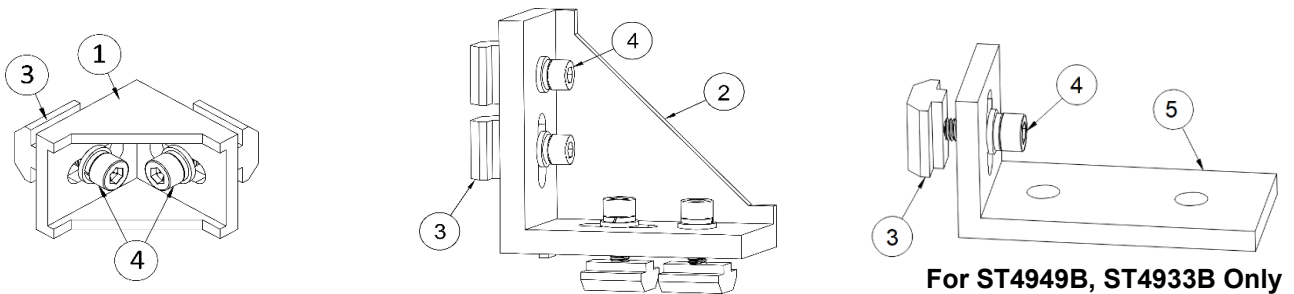

Key No.	Part Number	Model	Quantity
1	B3	Corner Bracket 4040	12
2	B1	Corner Bracket 4080	4
3	NS46	40M6 T-Nut	44(40)
4	FG620	M6x20 Galvanized Socket Head Screw with Lock Washer and Flat Washer	44(40)
5	B2	Angle Bracket	4

## 2. Y-BEAMS ORIENTATION FOR BASE

Aluminum extrusions may have slight bends from manufacturing. Position the flatter side of each Y-Beam (AL113 and AL114) facing upward, and the more curved sides facing outward along the left and right edges of the base. Ensure both beams curve inward toward each other, creating a gap in the center rather than at the ends. This central gap provides space to adjust the three middle X-cross bars.

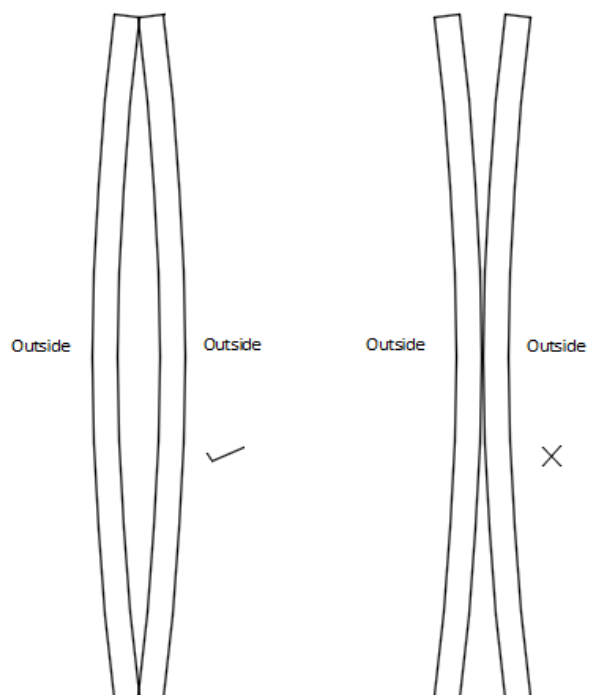

## 3. ASSEMBLING FRONT AND REAR X-CROSS BARS

**NOTE:**

IF YOUR MODEL IS ST4949F OR ST4933F WITH A STAND, SLIDE TWO 40M6 T-NUTS (5) INTO THE INNER SLOTS OF TWO X-CROSS BARS BEFORE ATTACHING THE CORNER BRACKETS 4080 (2).

- The 40M6 T-Nuts (3) and 40M5 T-Nuts (4) look nearly identical. Double-check to avoid mixing them up.
- Slide 40M6 T-Nuts (3) and 40M5 T-Nuts (4) into the top slots of the two X-Cross Bars (1) in the sequence shown in the diagram (3 4 3 3 4 3 3 4 3 3 4 3 3 4 3).
- Slide eight 40M8 T-Nuts (5) into the outer slots of the two X-Cross Bars (1).
- Slide four assembled Corner Brackets 4080 onto the side ends of the two X-Cross Bars (1).
- These Two X-Cross Bars (1) will form the front and rear X-cross members of the base unit.

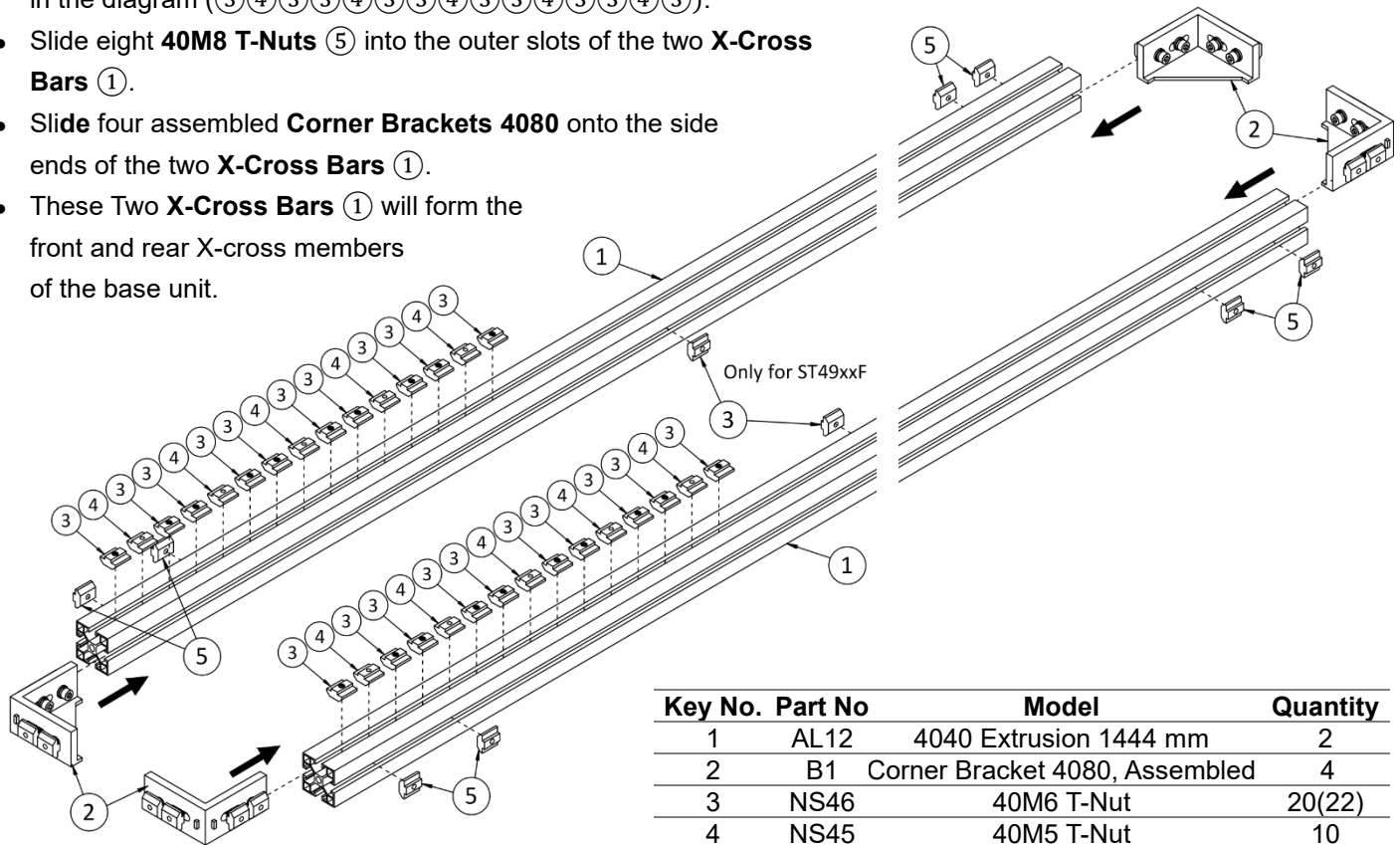

Key No.	Part No	Model	Quantity
1	AL12	4040 Extrusion 1444 mm	2
2	B1	Corner Bracket 4080, Assembled	4
3	NS46	40M6 T-Nut	20(22)
4	NS45	40M5 T-Nut	10
5	NS48	40M8 T-Nut	8

## 4. ASSEMBLING MIDDLE X-CROSS BARS

- Slide twelve assembled Corner Brackets 4040 (2) onto the side ends of the three X-Cross Bars (1).
- Slide 40M6 T-Nuts (3) and 40M5 T-Nuts (4) into the top slots of the three X-Cross Bars (1) in the sequence shown in the diagram (3 4 3 4 3 4 3 4 3 4 3).
- These three X-Cross Bars (1) will form the middle X-cross members of the base unit.

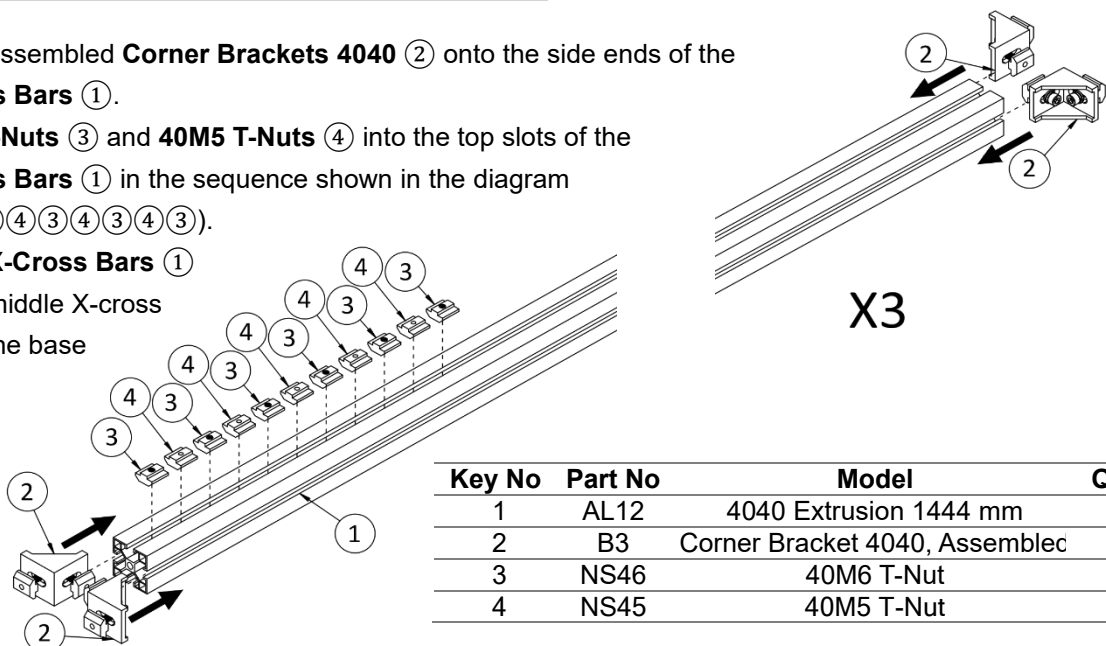

Key No	Part No	Model	Quantity
1	AL12	4040 Extrusion 1444 mm	3
2	B3	Corner Bracket 4040, Assembled	12
3	NS46	40M6 T-Nut	18
4	NS45	40M5 T-Nut	15

## 5. ASSEMBLING BASE FRAME

**NOTE:**

IF YOUR MODEL IS ST4949F OR ST4933F WITH A STAND, DO NOT MOUNT THE FOUR ANGLE BRACKETS ④ TO THE SIDES OF THE Y-BEAMS ①. THESE BRACKETS WILL BE ATTACHED TO THE STAND BEAMS LATER IN THE “STAND ASSEMBLY” SECTION.

- Slide three assembled middle X-Cross Bars ③ onto the left and right Y-Beams ①.
- Slide four assembled Angle Brackets ④ onto the left and right Y-Beams ① (ST4949B, ST4933B only).
- Slide two assembled front and rear X-Cross Bars ② onto the left and right Y-Beams ①.
- Keep four Angle Brackets ④ loose for later adjustment.

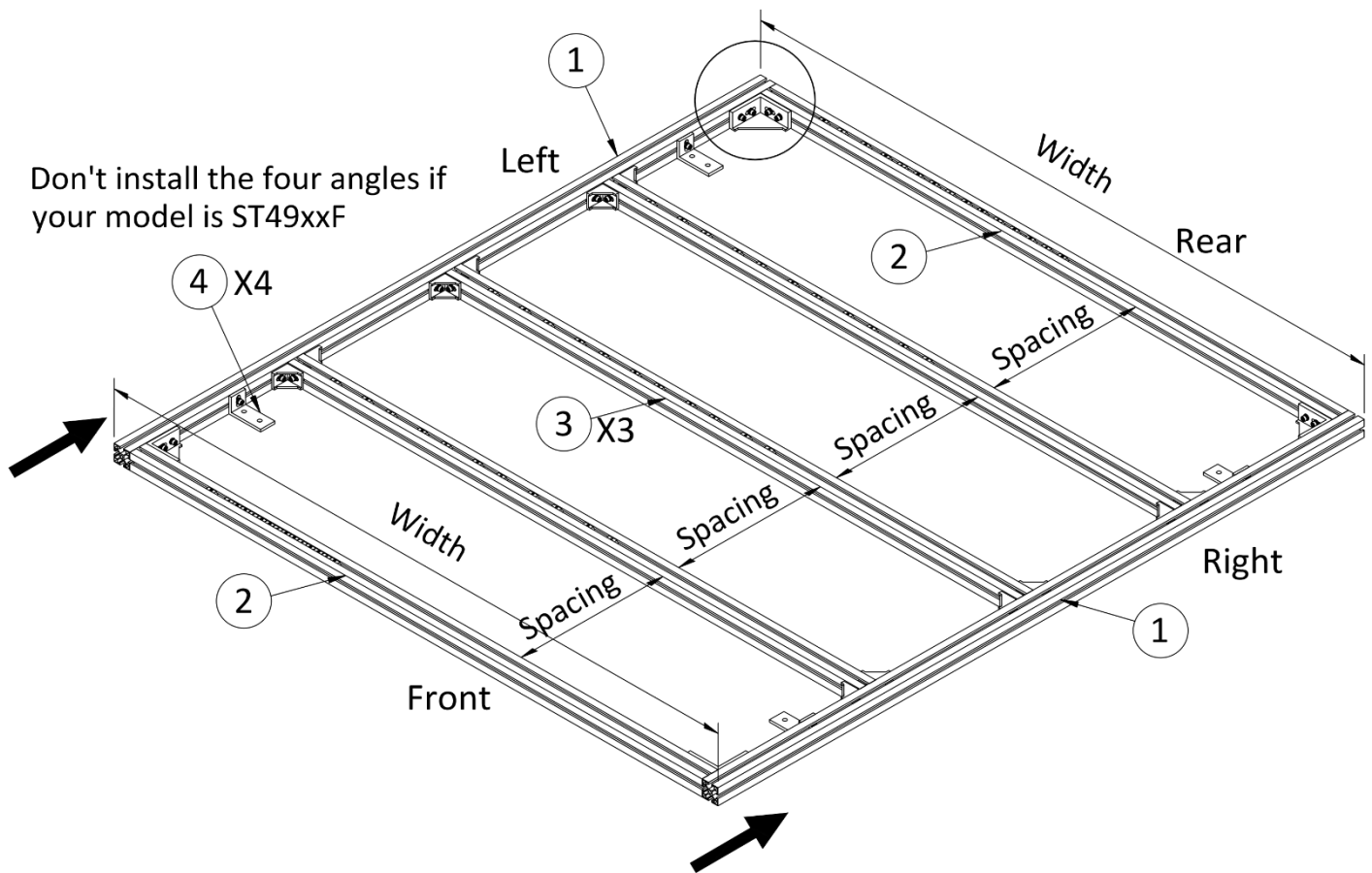

		ST4949B, F			ST4933B, F
Key No.	Part No	Model	Part No	Model	Quantity
1	AL114	4040 Extrusion 1630 mm	AL113	4040 Extrusion 1210 mm	2
2	AL12	Front and Rear X-Cross Bars, Assembled	AL12	Front and Rear X-Cross Bars, assembled	2
3	AL12	Middle X-Cross Bars, Assembled	AL12	Middle X-Cross Bars, assembled	3
4	B2	Angle Bracket, Assembled	B2	Angle Bracket, assembled	4

- To Align the four ends of the front and rear **X-Cross Bars** ② flush with the top and end surfaces of the **Y-Beams** ①, follow these steps:
  - Hand-tighten two M6x20 ⑦ screws to secure the **Corner Bracket** ⑤ to the **X-Cross Bar** ②.
  - Align the **X-Cross Bar** ② flush with the end surfaces of the **Y-Beam** ①, then tighten two M6x20 screws ⑥ to secure the **Corner Bracket** ④ to the **Y-Beam** ①, using an engineer's square ⑧ (not included) or straight edge for assistance if needed.
  - Loosen the two M6x20 screws ⑦, adjust the **X-Cross Bar** ② until it contacts the **Y-Beam** ① and aligns flush with its top surface, using an engineer's square ⑧ and bar clamp (not included) for assistance if needed.
  - Retighten the two M6x20 screws ⑦.

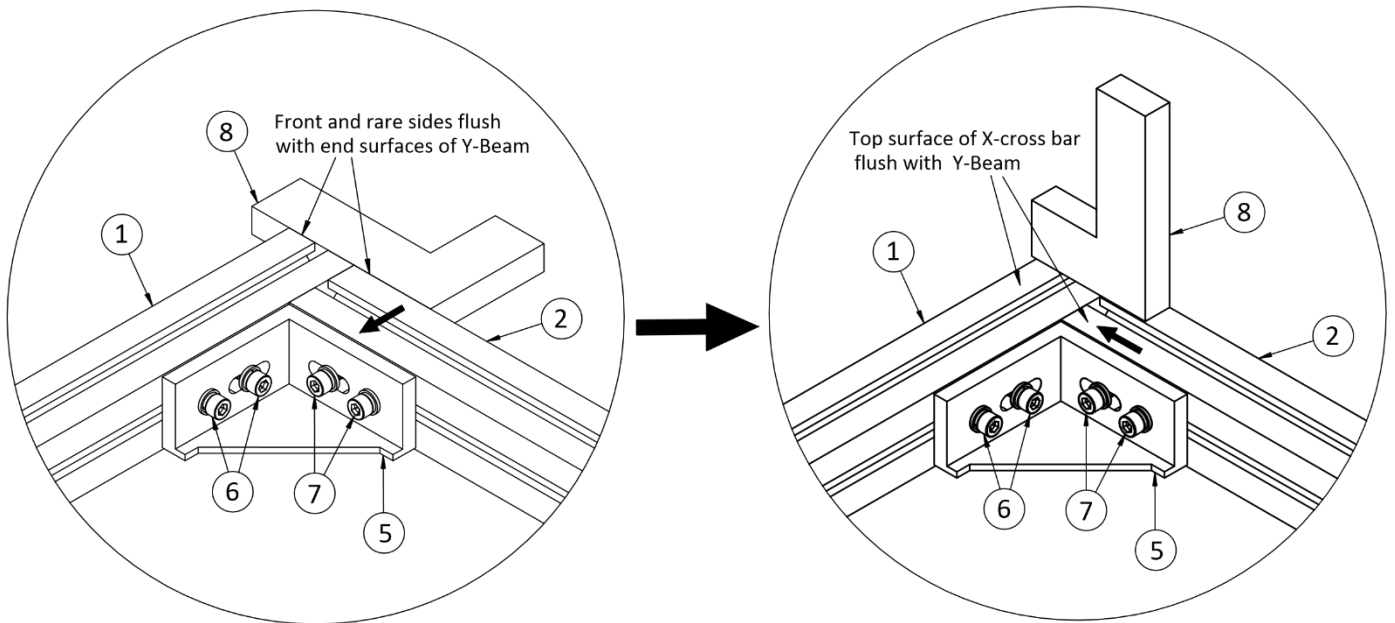

- Confirm** that the difference between the front-end and rear-end widths is less than 0.5 mm (0.02”).
- Adjust** the spacings between **X-cross bars** ②③ to 357.5 mm (ST4949) or 252.5 mm (ST4933). This spacing is based on the specified hole distance in the MDF wasteboards as indicated in the “WASTEBOARDS” section above.
- If** the MDF wasteboards’ hole pattern is changed, reposition the X-Cross Bars to match the new hole spacing minus 40 mm. Be aware that the T-tracks will need new countersunk holes, as the originals will not align.
- Fully tighten** all screws to secure the three middle **X-Cross Bars** ③, ensuring their top surfaces are flush with the **Y-Beams** ①.

## 6. MOUNTING BASE FRAME ONTO BENCH TOP

**NOTE:**

**FOR ST4949F AND ST4933F MODELS WITH A STAND, SKIP NEXT TWO SECTION, COMPLETE THE “STAND ASSEMBLY” SECTION, THEN PROCEED TO THE “ASSEMBLING WASTEBOARDS ONTO BASE FRAME” SECTION.**

- The machine must be mounted to a flat, solid and well leveled tabletop (not included) with rigid support.
- The recommended tabletop height is 787 mm (31”) or a height that fits your preference.
- Minimum size of tabletop is 1676 mm (66”) (width) X 1744 mm (68.66”) (depth) for ST4949 or 1676 mm (66”) (width) X 1324 mm (52.13) (depth) for ST4933. This provides the necessary clearance between the base frame and edge of the table, as shown in the diagram.
- Leave at least 500 mm (20”) of clearance around the table for easy access.
- Place the base frame on the level tabletop.
- Adjust the four **Angle Brackets** ① to level the top surface of the base. Shim the bottom of the base if needed.
- Fully tighten four **M6x20 Screw Sets** ② to secure four angle brackets to the base frame.
- Secure four angle brackets to the tabletop using four **M8x25 Tapping Screws** ③.

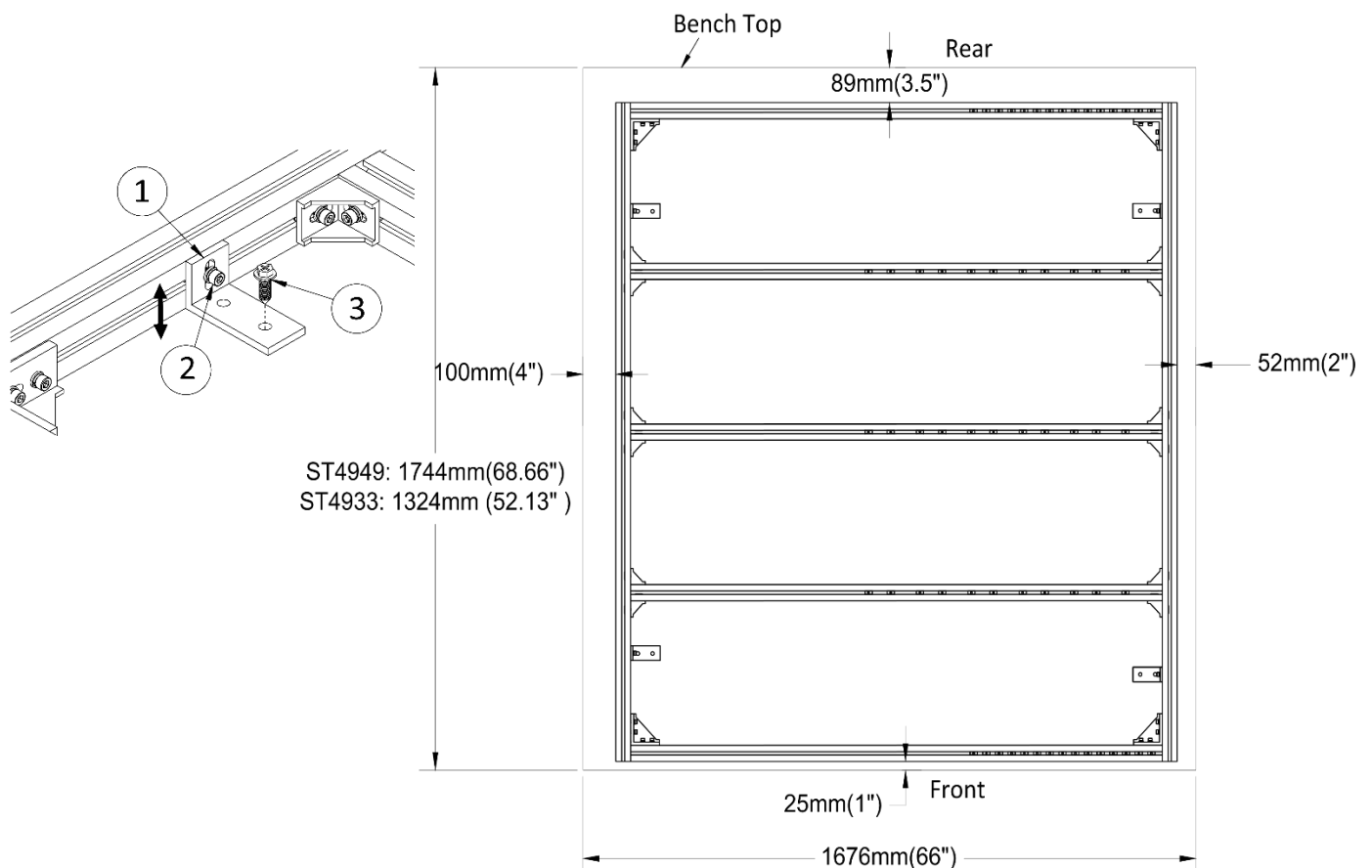

## 7. INSTALLING SWITCH BOX

**FOR ST4949B AND ST4933B WITHOUT STAND ONLY:**

- Mount the switch box to the left side or front left corner of the work bench using four **M4x20 Galvanized Round Head Self- Tapping Screws**. The power cord will connect to the controller, which is located on the left side of the machine.

## 8. ASSEMBLING WASTEBOARDS ONTO BASE FRAME

**NOTE:**

**FOR ST4949F AND ST4933F MODELS WITH A STAND, COMPLETE THE “STAND ASSEMBLY” SECTION BEFORE PROCEEDING.**

- Position two narrow MDF boards (90 mm wide) ④ on the left and right sides of the base top, along with four wider MDF boards (285 mm wide) ④ in the center, separated by five aluminum **T-Tracks**.
- Attach five aluminum **T-Tracks** ① to the **X-Cross Bars** ② of the base by threading **M5x12 Flat Head Screws** ③ into **40M5 T-Nuts** in the slots of the **X-Cross Bars**.
- Attach six MDF boards ④ to the **X-Cross Bars** of the base by threading **M6x25 Flat Head Screws** ⑤ into **40M6 T-Nuts** in the slots of the **X-Cross Bars**.
- Align all MDF boards and aluminum **T-Tracks** to ensure they do not cover the left and right **Y-Beams** or extend beyond the front and rear edges of the base.

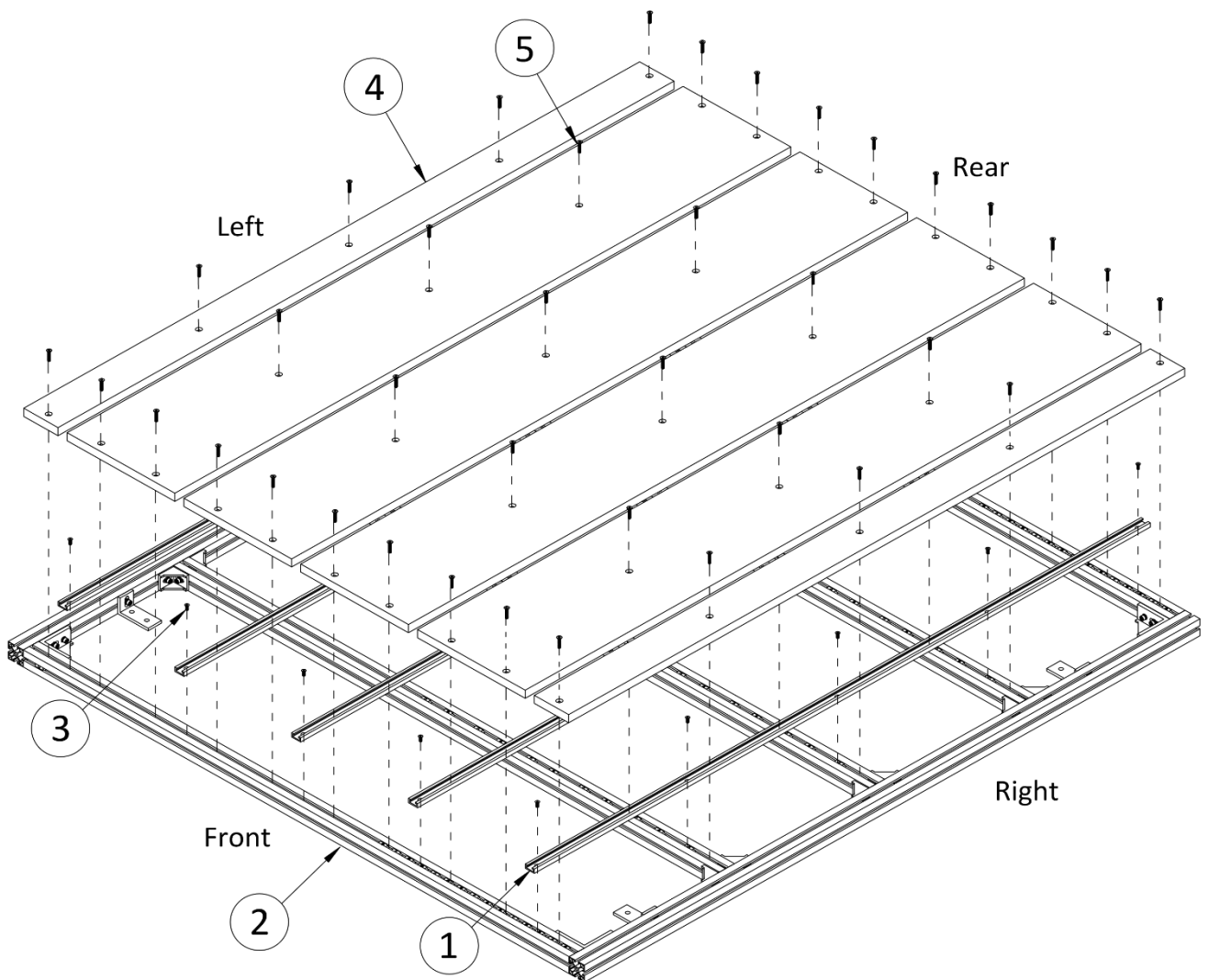

Key No.	Part Number	Model	Quantity
1	AL64, AL63	T-Track 1630 mm, 1210 mm	5
2	AL12	Front and Rear X-Cross Bars	2
3	FG512	M5x12 Galvanized Flat Head Screw	25
4		MDF Wasteboard	6
5	FG625	M6x25 Galvanized Flat Head Screw	38

# STAND

# PARTS LIST

\* FOR ST4949B AND ST4933B MODELS WITHOUT A STAND, SKIP THIS SECTION.

## 1. PARTS INCLUDED

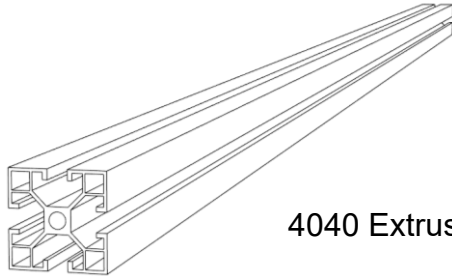

4040 Extrusion

Part Number	AL13	AL14	AL15
Length	656 mm	433 mm	320 mm
Quantity	4	4	4
Position	Leg	Cross Brace	Cross Brace

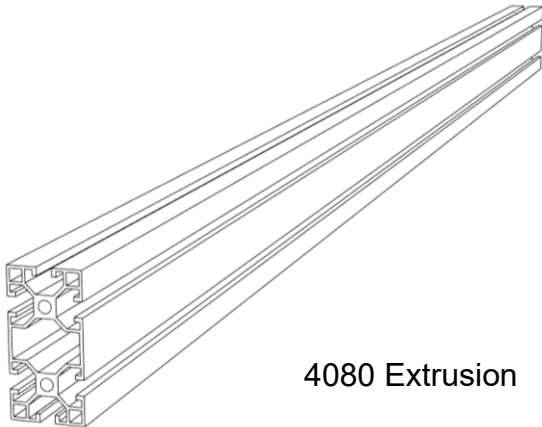

4080 Extrusion

	ST4949F	ST4933F
Part Number	AL22	AL234
Length	1524 mm	1550 mm
Quantity	2	2
Position	X-Beam	Y-Cross Bar

Model	Corner Bracket 4040	Joining Plate 4080	Brace Bracket	Foot Adaptor
Part Number	B3	B4	B5	B7
Quantity	16	2	16	4
Position	Cross Beams	X-Beam	Cross Brace	Leveling Foot

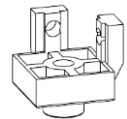
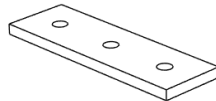
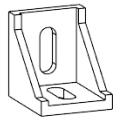

Model	Leveling Foot	End Cap	Anchor Fastener	Switch Box Bracket
Part Number	B8	EC1	B6	Y7
Quantity	4	4	8	3

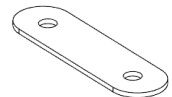
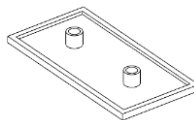
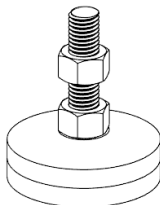

# STAND

# PARTS LIST

<b>Model</b>	30M8 T-Nut	40M6 T-Nut	40M8 T-Nut	30M5 Roll-in T-Nut
<b>Part Number</b>	NS38	NS46	NS48	NR35
<b>Quantity</b>	16	46	16	3

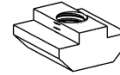
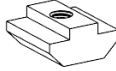
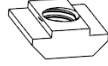

<b>Model</b>	M4x14 Stainless Steel Pan Head Screw with Flat Washer, Lock Washer and Nut	M5x16 Galvanized Socket Head Screw with Flat Washer and Lock Washer
<b>Part Number</b>	FS414	FG516B
<b>Quantity</b>	3	3

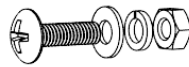

<b>Model</b>	M6x20 Galvanized Socket Head Screw with Lock Washer and Flat Washer	M8x20 Galvanized Socket Head Screw with Lock Washer and Flat Washer
<b>Part Number</b>	FG620	FG820
<b>Quantity</b>	46	32

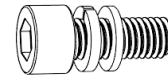
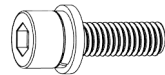

<b>Model</b>	M8x25 Galvanized Socket Head Screw with Lock Washer and Flat Washer	M8x25 Galvanized Socket Head Screw	Switch Box
<b>Part Number</b>	FG825	FG825B	SB
<b>Quantity</b>	8	8	1

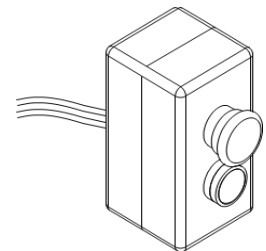
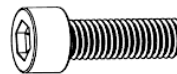

# STAND

# ASSEMBLY

## FOCUS ON:

- Positioning the machine with sufficient clearance for easy access.
- Leveling the top of the base by adjusting the four leveling feet.

## 1. ASSEMBLING BRACKETS

- Assemble all brackets as shown in the diagram, using 30M8 T-nuts (15), 40M6 T-nuts (9), and 40M8 T-nuts (10), **Galvanized Socket Head Screw Sets (M6x20 (11), M8x20 (12), and M8x25 (13)(14))**.
- Fully tighten all **M8 X 20 Galvanized Socket Head Screw Sets (12)** to secure the **Brace Brackets (5)** to the eight **Cross Braces (7)(8)**.
- Keep all remaining screws loosely fastened.

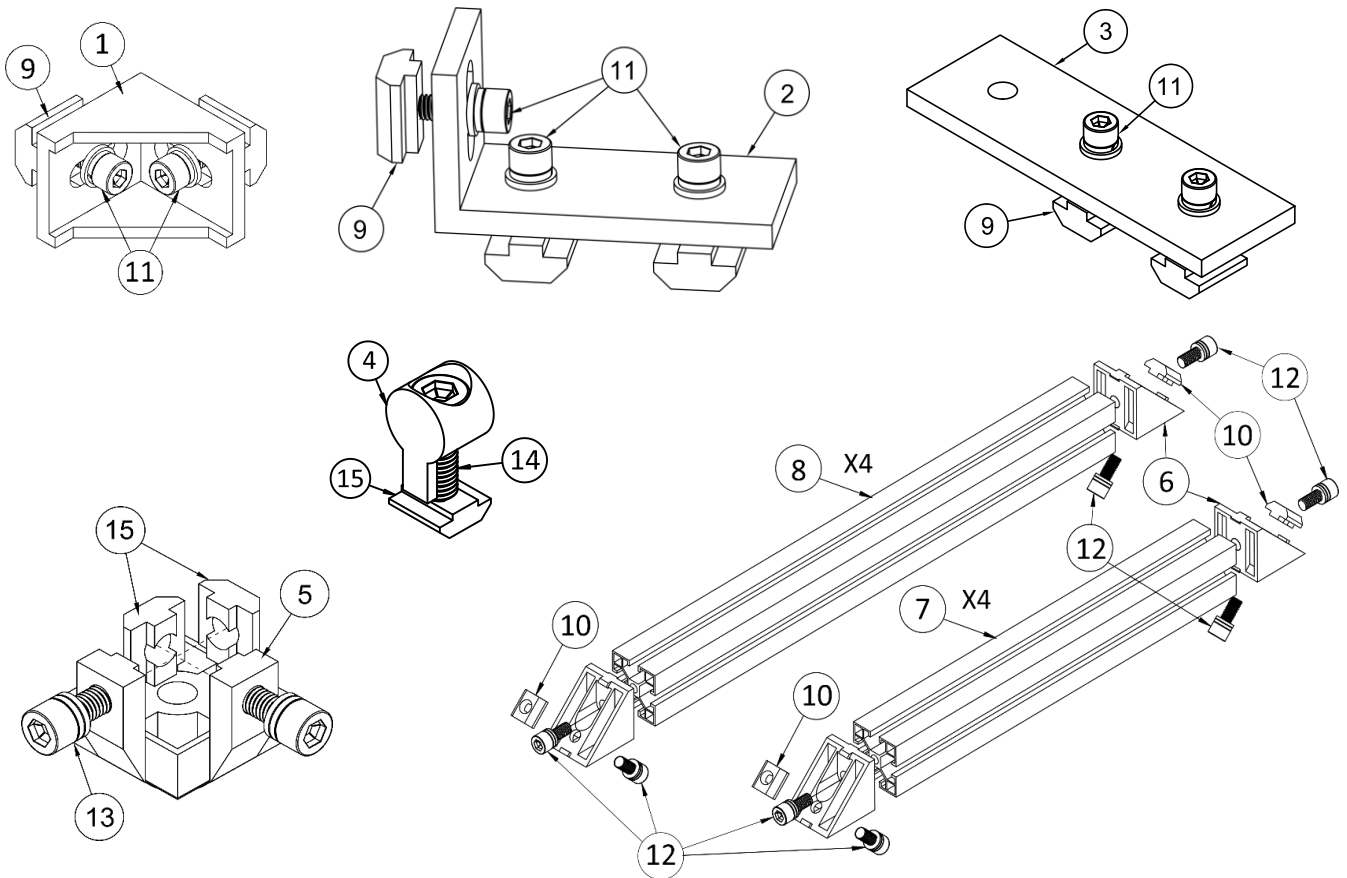

Key No	Part Number	Model	Quantity
1	B3	Corner Bracket 4040	16
2	B2	Angle Bracket	4
3	B4	Joining Plate 4080	2
4	B6	Anchor Fastener	8
5	B7	Foot Adaptor	4
6	B5	Brace Bracket	16
7	AL15	Cross Brace 320 mm	4
8	AL14	Cross Brace 433 mm	4
9	NS46	40M6 T-Nut	48
10	NS48	40M8 T-Nut	16
11	FG620	M6 x 20 Galvanized Socket Head Screw with Lock Washer and Flat Washer	48
12	FG820	M8 x 20 Galvanized Socket Head Screw with Lock Washer and Flat Washer	32
13	FG825	M8 x 25 Galvanized Socket Head Screw with Lock Washer and Flat Washer	8
14	FG825B	M8 x 25 Galvanized Socket Head Screw	8
15	NS38	30M8 T-Nut	16

## 2. ATTACHING CROSS BRACES TO BASE

- Turn the assembled base frame upside down.
- Slide four assembled **433 mm Cross Braces** ① onto the left and right Y-beams of the base.
- Slide four assembled **Angle Brackets** ② onto the left and right Y-beams of the base.
- Position two **Angle Brackets** ② on the left base beam 40 mm away from each end and the other two **Angle Brackets** ② on the right base beam 60 mm away from each end.

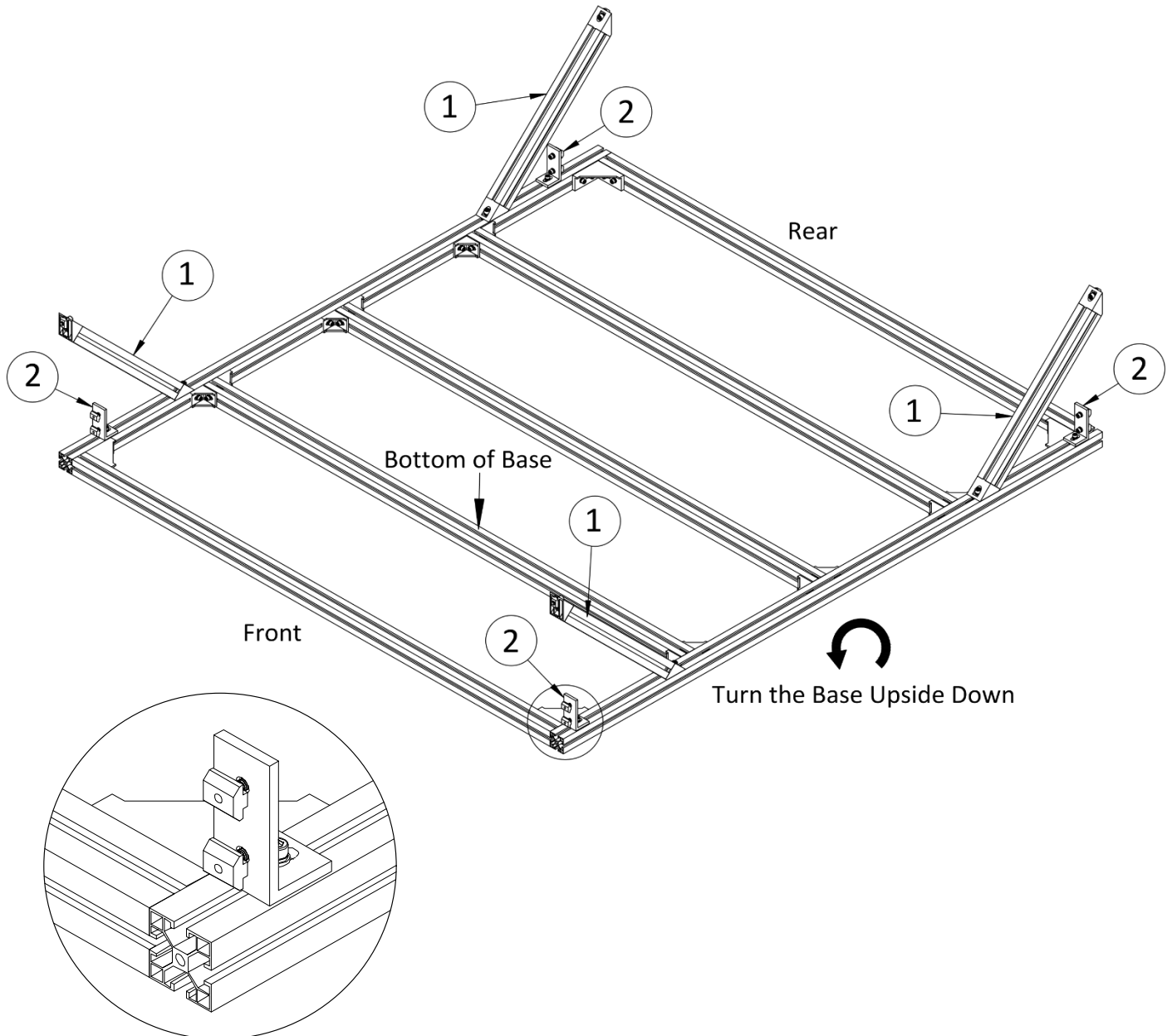

Key No.	Part Number	Model	Quantity
1	AL14	Cross Brace 433 mm	4
2	B4	Assembled angle bracket	4

## 3. ASSEMBLING REINFORCEMENT BEAMS

- Slide eight assembled **Corner Brackets 4040** (1) onto the side ends of two **Y-Cross Bars** (2). These two extrusions (2) will form the middle Y-cross members of the stand.
- Slide two **Joining Plates** (4) onto the two **X-Cross Bars** (2).
- Slide two **Y-Cross Bars** (2) onto two **X-Cross Bars** (3) from both sides, ensuring the two **Joining Plates** (4) remain centered on the **X-Cross Bars**, as shown in the diagram. Position the two **Y-Cross Bars** (2) evenly and square to the **X-Cross Bars** (3).
- Align all four beams so their top surfaces are flush, as indicated in the diagram.
- Hand-tighten all screws.

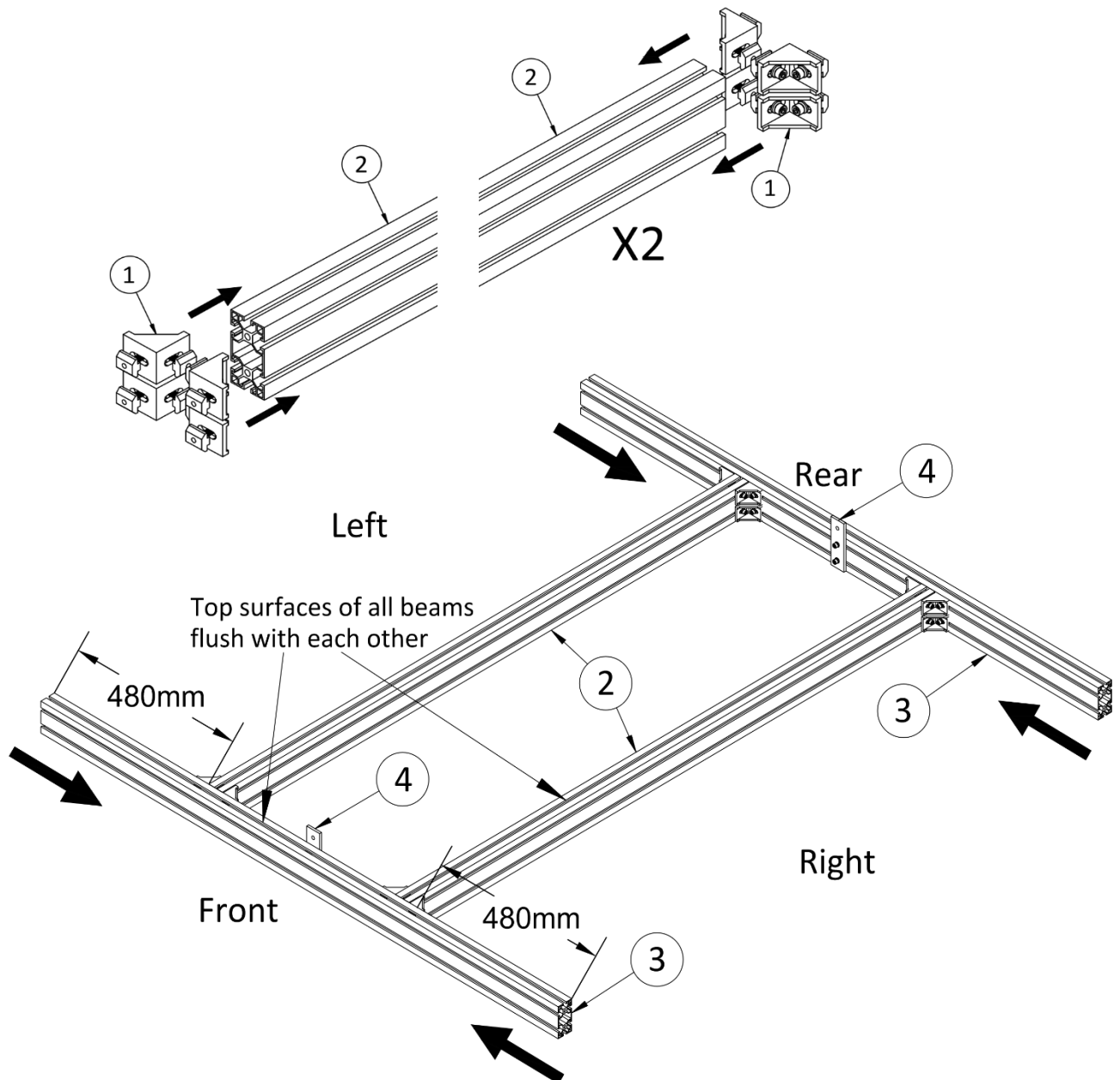

Key No.	Part Number	Model	Quantity
1	B3	Corner Bracket 4040	16
2	AL234, AL233	Y-Cross Bar, 1550 mm (ST4949F), 1130 mm (ST4933F)	2
3	AL22	X-Cross Bar, 1524 mm	2
4	B4	Assembled Joining Plate 4080	2

## 4. ATTACHING REINFORCEMENT BEAMS TO BASE

- Set the assembled reinforcement stand beam unit onto the base frame, then slide the four **Angle Brackets** ① into the ends of the front and rear **X-Cross Bars** ③.
- Align the reinforcement beams flush with the base frame unit.
- Secure the two **Joining Plates** ④ to the **40M6 T-Nuts** previously inserted into the front and rear base frame bars ⑥ using two **M6x20 Galvanized Socket Head Screw Sets** ⑤.
- Fully tighten all screws on the four **Angle Brackets** ① and the two **Joining Plates** ④ to secure the reinforcement stand beam unit to the base.
- Secure the two **Y-Cross Bars** ② to the **X-Cross Bars** ③ by fully tightening the screws on them.

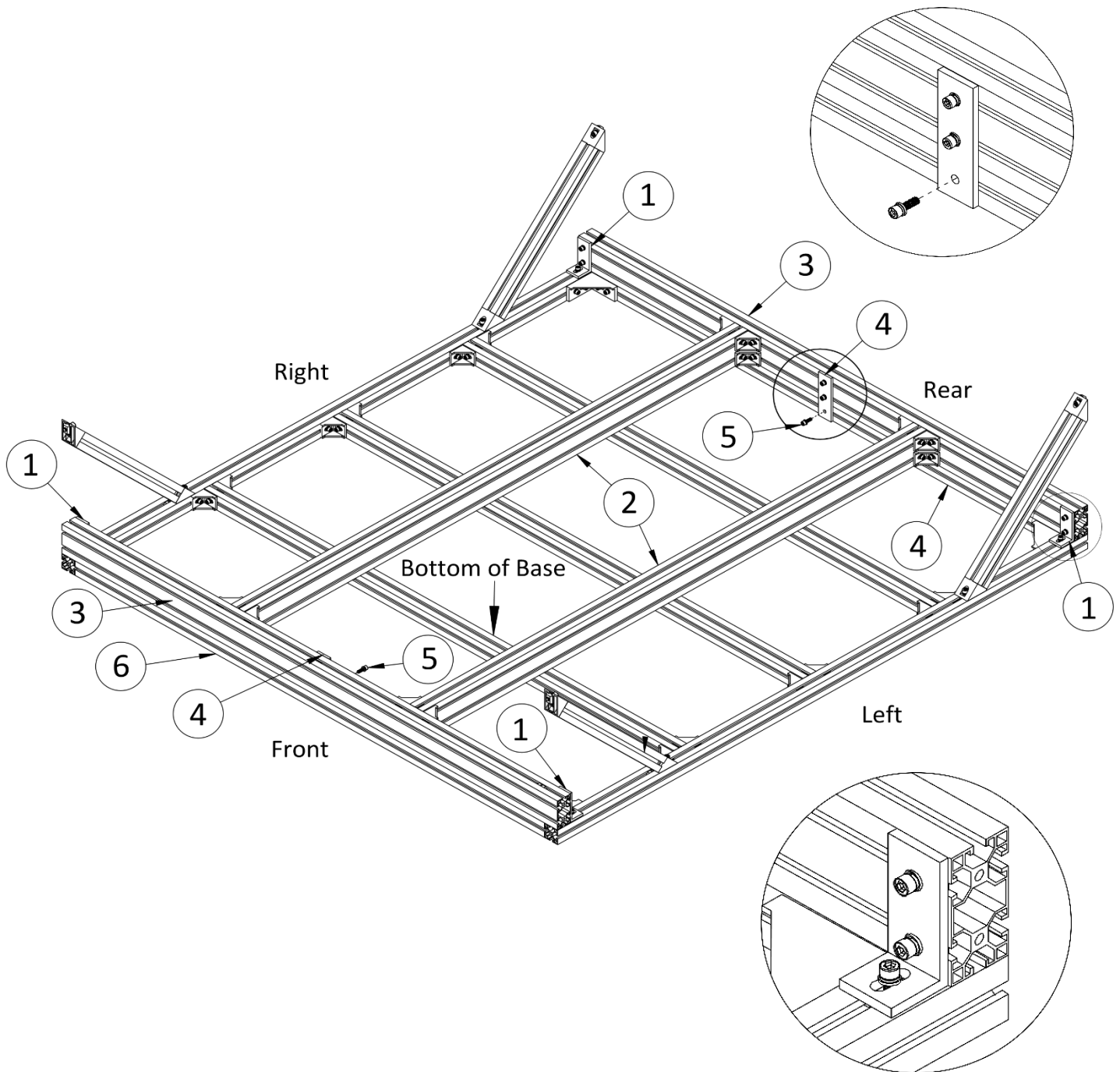

Key No	Part Number	Model	Quantity
5	FG620	M6x20 Galvanized Socket Head Screw with Lock Washer and Flat Washer	2

## 5. ATTACHING CROSS BRACES AND LEGS TO STAND

- Slide four assembled **320 mm Cross Braces** ① onto the front and rear **X-Cross Bars** ② of the stand.
- Slide four assembled **Anchor Fasteners** ③ onto the ends of front and rear **X-Cross Bars** ②. One on each end.
- Position four **656 mm Legs** ④ with their pre-drilled hole ends facing downward, and orient the holes left and right to align with the **Anchor Fasteners** ③. Slide the **Legs** ④ down into place while attaching all eight **Cross Braces** ①.
- Align the **Legs** ④ flush with the front and rear **X-Cross Bars** ②. Attach all eight **Anchor Fasteners** ③ to the pre-drilled holes in the legs. Fully tighten the screws on the **Anchor Fasteners** ③ using an Allen key to secure all four **Legs** ④.
- Fully tighten the screws on all eight **Cross Braces** ① to completely secure the **Legs** ④.

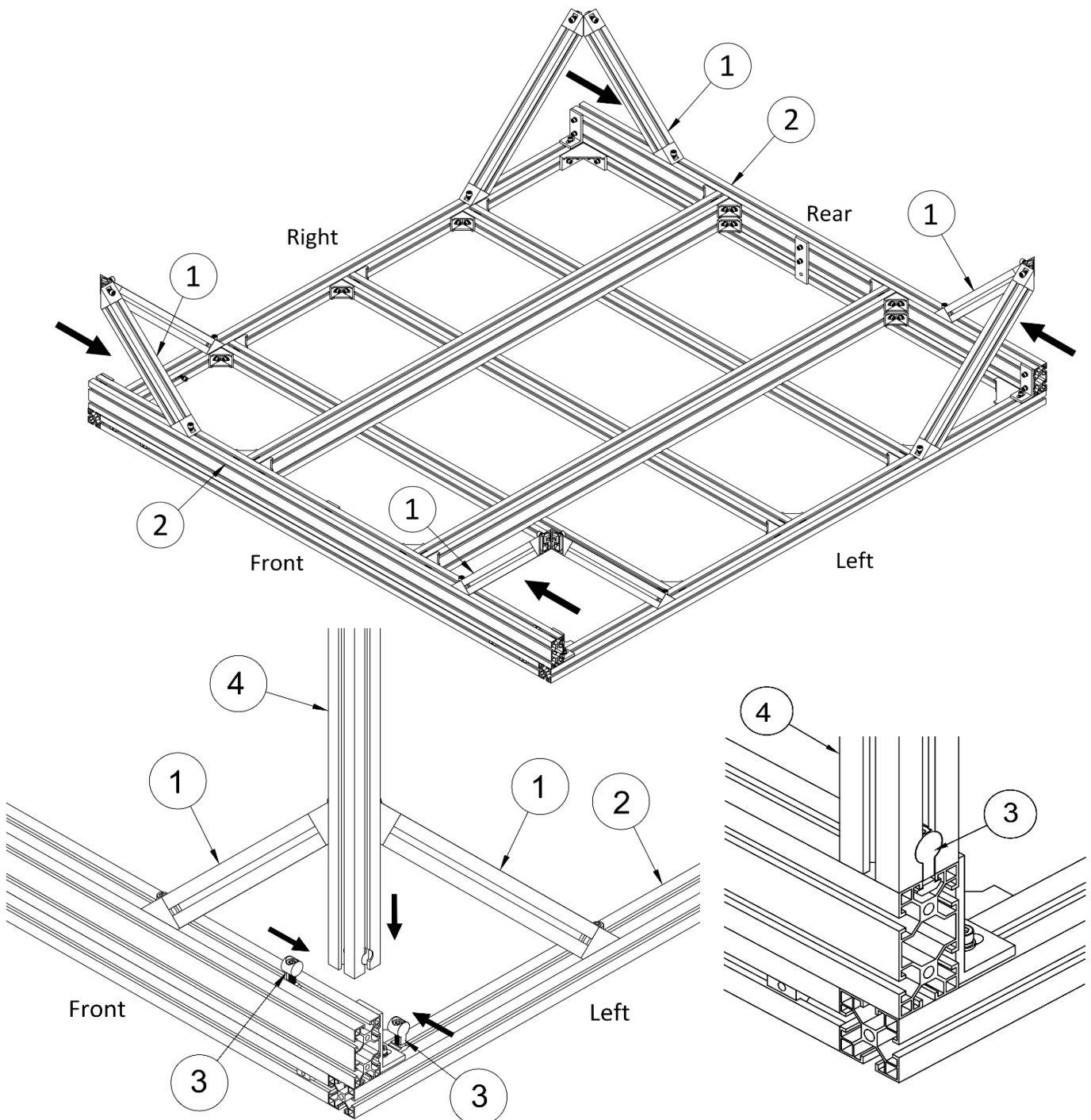

Key No.	Part Number	Model	Quantity
1	AL15	Cross Brace 320 mm	4
3	B6	Anchor Fastener	8
4	AL13	Leg, 656 mm	4

## 6. ASSEMBLING LEVELING FEET

- Attach four **Foot Adapters** (2) to the **Legs** (1) and fully tighten all screws to secure them in place.
- Screw four **Leveling Feet** (3) into the **Foot Adapters** (2).

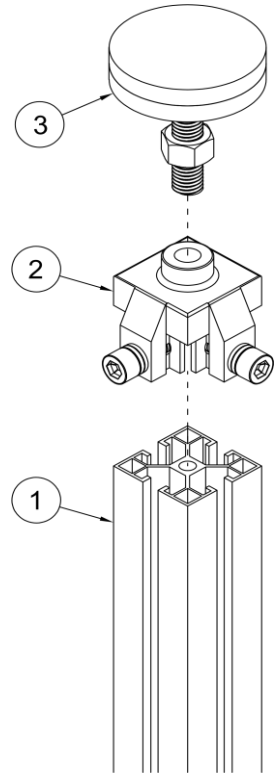

## 7. POSITIONING AND LEVELING BASE AND STAND

- Flip the assembled base frame and stand back to its upright position and place it in the location where it will be used.
- Ensure at least 500 mm (20") of clearance around the machine for easy access.
- Use a 1200 mm (48") (not included) level to level the base top by adjusting the height of the four leveling feet, then tighten the nuts on the leveling feet to secure them.
- Attach four end caps to both ends of the front and rear X-cross bars.

## 8. INSTALLING SWITCH BOX

- Open the **Switch Box** (1).
- Secure three **Switch Box Brackets** (3) to the back of the **Switch Box** (1), oriented as shown in the diagram with red emergency stop button positioned above, using three **M4x14 Stainless Steel Pan Head Screw Sets** (4) with flat washers, lock washers and nuts.
- Tighten the screws, then reinstall the front cap of the **Switch Box** (1) back.

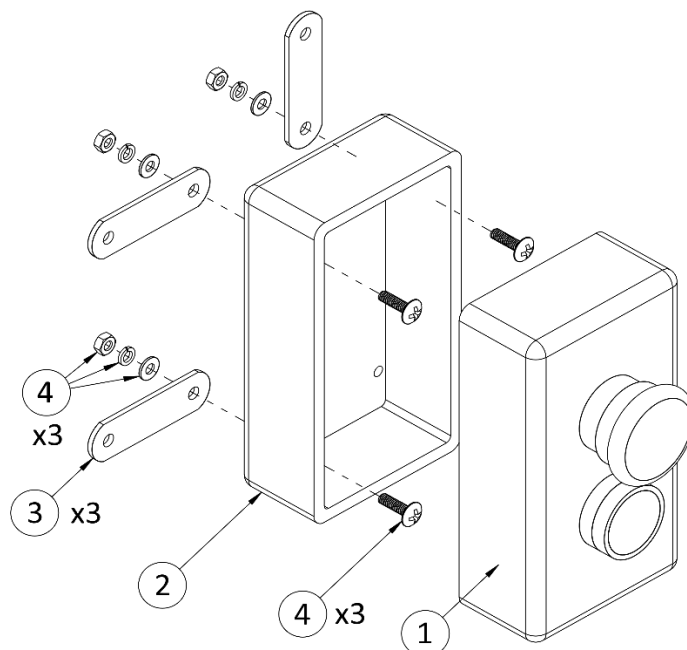

# STAND

# ASSEMBLY

Key No.	Part Number	Model	Quantity
1	SB	Front Cap of Switch Box	1
2	SB	Bottom Case of Switch Box	1
3	Y7	Switch Box Bracket	3
4	FS414	M4x14 Stainless Steel Pan Head Screw with Flat Washer, Lock Washer and Nut	3

- The Switch Box mounts on the front-left corner of the stand.
- Insert three 30M5 Roll-in T-Nuts into the back slots of the stand at the spots indicated by arrows in the diagram.
- Secure three **Switch Box Brackets** ③ to the Roll-in T-Nuts from inside the stand, using three **M5x16 Galvanized Socket Head Screw Sets** ④ with flat washers and lock washers.

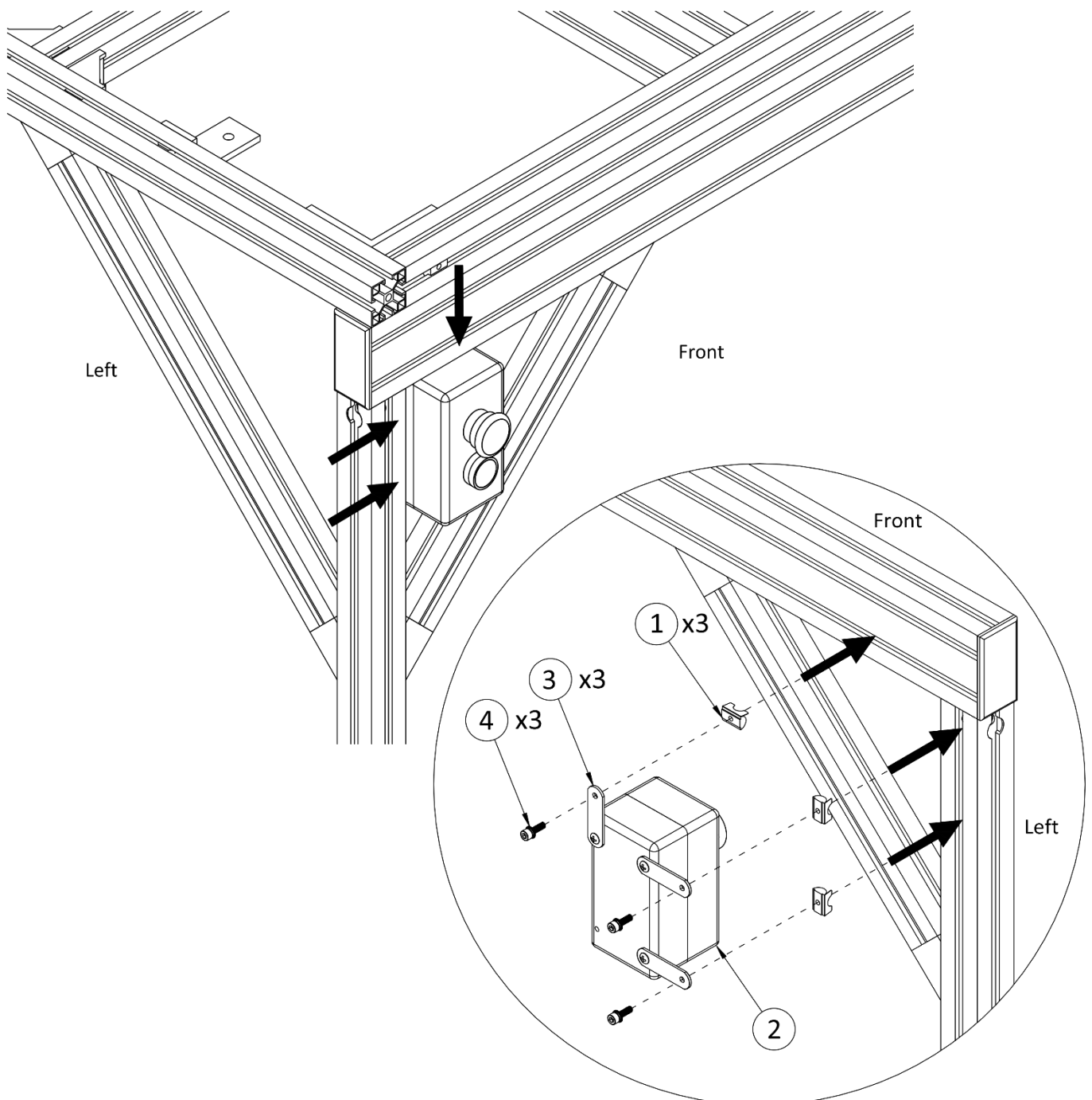

# STAND

# ASSEMBLY

THE BASE FRAME AND STAND ARE NOW FULLY ASSEMBLED AND POSITIONED IN THE WORKING AREA. PROCEED TO SECTION "BASE ASSEMBLY – 10. ASSEMBLING WASTEBOARDS ONTO BASE FRAME".

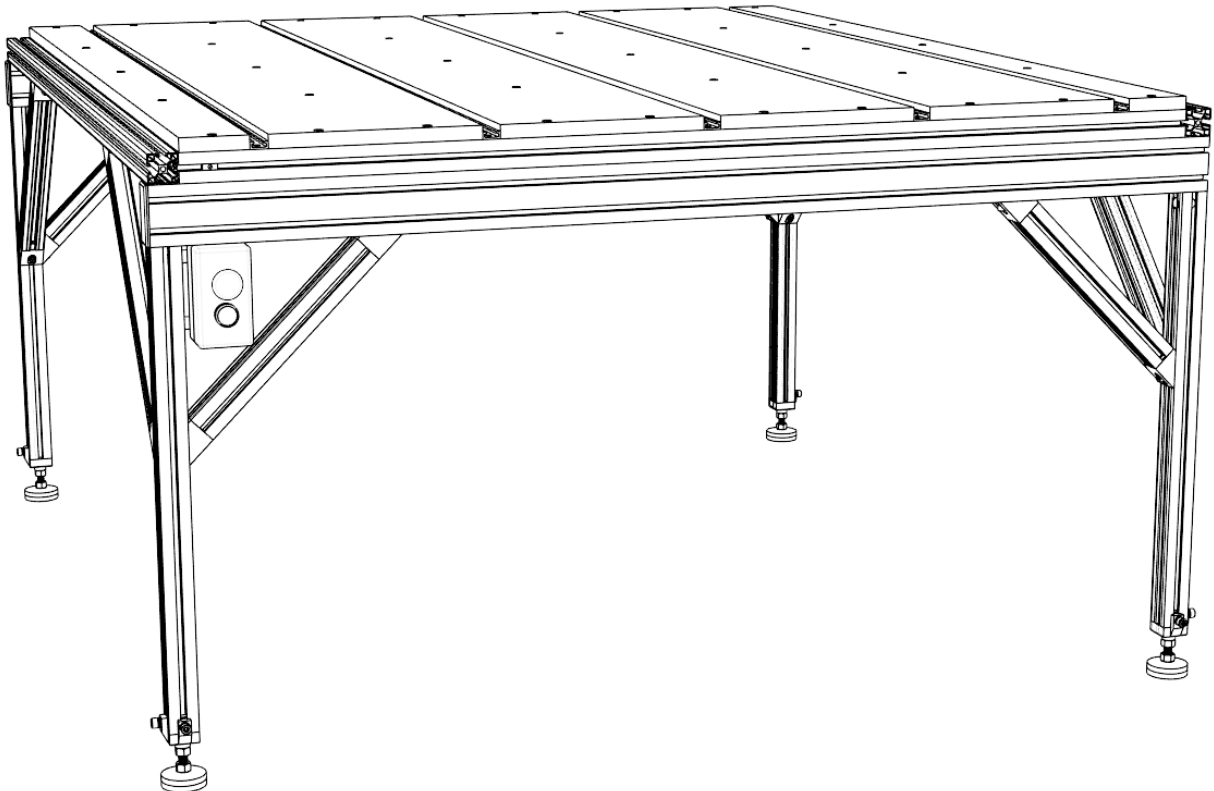

# XYZ UNIT

# PARTS LIST

## 1. PARTS INCLUDED

	ST4949B, F	ST4933B, F	ST4949B, F	ST4933B, F
<b>Model</b>	Y-L Assembly	Y-L Assembly	Y-R Assembly	Y-R Assembly
<b>Part Number</b>	YL49	YL43	YR49	YR43
<b>Length</b>	1630 mm	1210 mm	1630 mm	1210 mm
<b>Quantity</b>	1	1	1	1

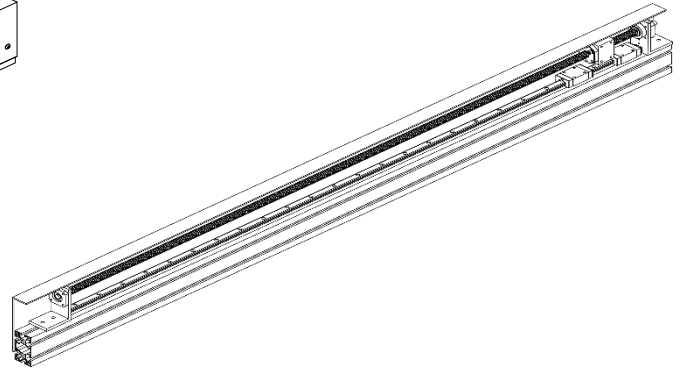
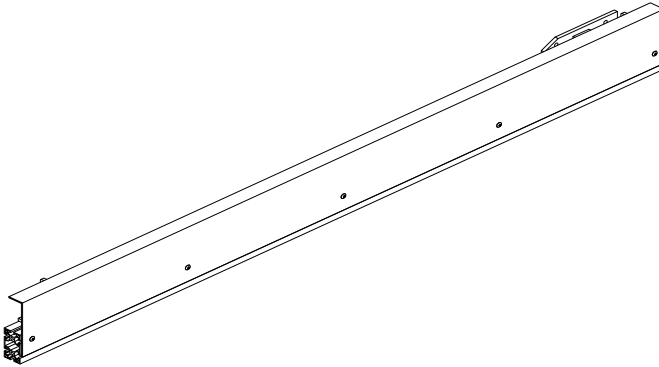

<b>Model</b>	X-Assembly	Z-Assembly
<b>Part Number</b>	X49	Z49
<b>Quantity</b>	1	1

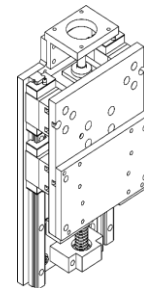
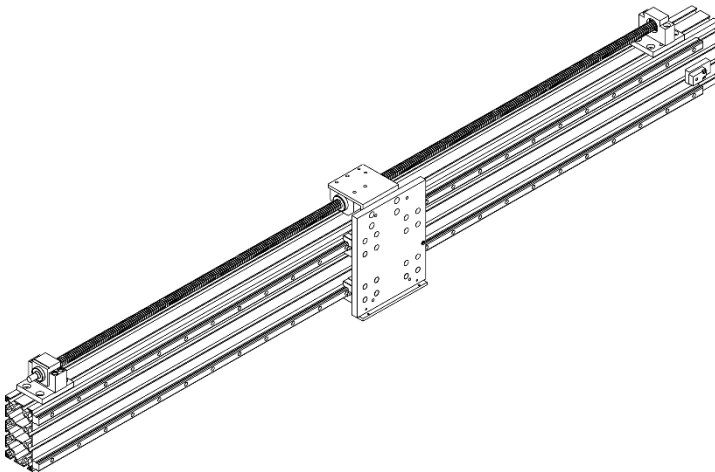

<b>Model</b>	Back Y-Joining Plate	Front Y-Joining Plate	XY-Joining Plate	XY-Joining Plate
<b>Part Number</b>	Y4	Y5	XYL	XYR
<b>Quantity</b>	2	2	1	1

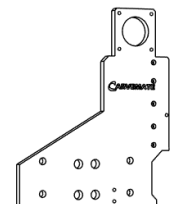
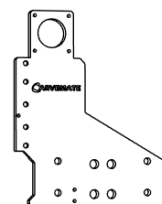
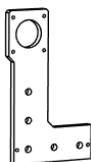

# XYZ UNIT

# PARTS LIST

Model	X-Back Plate	30M6 T-Nut	M6x16 Black Socket Head Screw with Lock Washer and Flat Washer
Part Number	X7	NS36	FB616
Quantity	2	16	4

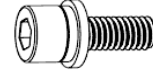
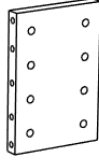

Model	M6x20 Black Socket Head Screw with Lock Washer and Flat Washer	M6x22 Black Socket Head Screw with Lock Washer and Flat Washer
Part Number	FB620	FB622
Quantity	10	16

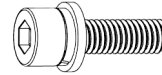
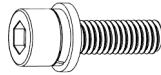

Model	M8x25 Black Socket Head Screw with Lock Washer and Flat Washer	M8x30 Black Socket Head Screw with Lock Washer, Flat Washer x 2 and Nut
Part Number	FB825	FB830
Quantity	20	8

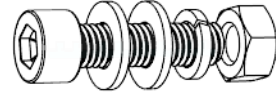
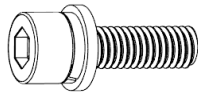

## FOCUS ON:

- Aligning the left XY-joining bracket so the X-motor lines up with the ball screw on the X-assembly.
- Ensuring the X-assembly sits squarely across both left and right L-shaped carriages of the Y-assemblies.
- Aligning the left and right Y-assemblies to be parallel.

## 1. ASSEMBLING Y-ASSEMBLIES TO BASE

- Attach the **Front and Rear Y-Joining Plate** (3)(5) to the base's left front and rear **X-Cross Bars** by threading four **M8x25 Black Socket Head Screw Sets** (4) into the four **40M8 T-Nuts** previously inserted into the **X-Cross Bars**.
- Position the **Y-L Assembly** (1) on top of the base's left **Y-Beam** (2), aligning it flush with the side of the **Y-Beam** (2).
- Secure the **Front Y-Joining Plates** (3) to the front ends of the **Y-L Assembly** (1) and the base's **Y-Beam** (2) using three **M8x25 Black Socket Head Screw Sets** (4) with flat washers and lock washers.
- Secure the **Back Y-Joining Plates** (5) to the rear ends of the **Y-L Assembly** (1) and the base's **Y-Beam** (2) using three **M8x25 Black Socket Head Screw Sets** (4) with flat washers and lock washers.
- Don't overtighten the screws.
- Repeat the same process for the **Y-R Assembly** (1).
- Remove the **L-shaped covers** (6) from both **Y-Assemblies** (1) by unscrewing ten Phillips round head screws (eight for ST4933); do not lose the ten plastic spacers located behind the cover. The covers will be reinstalled after completing cable wiring.

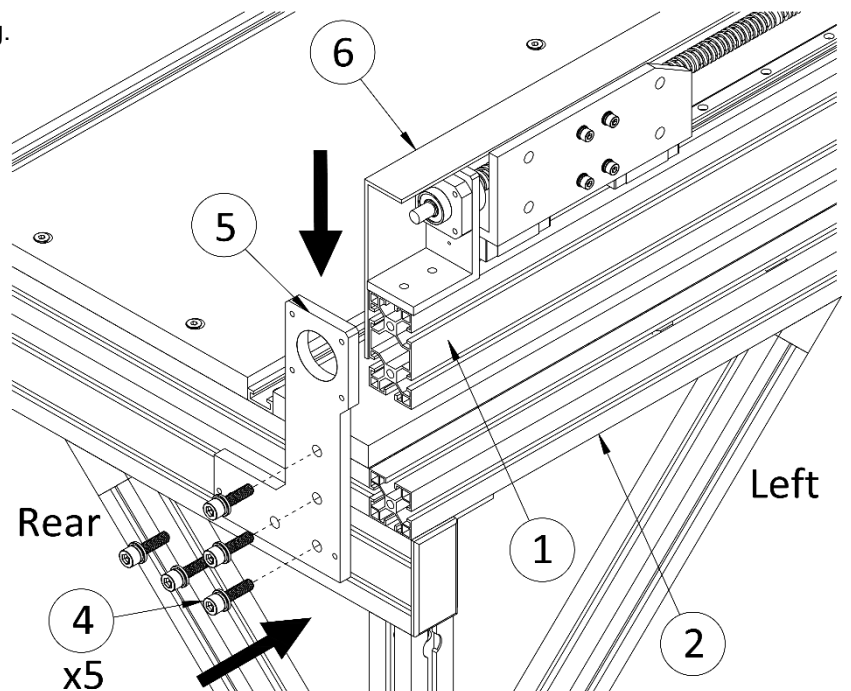
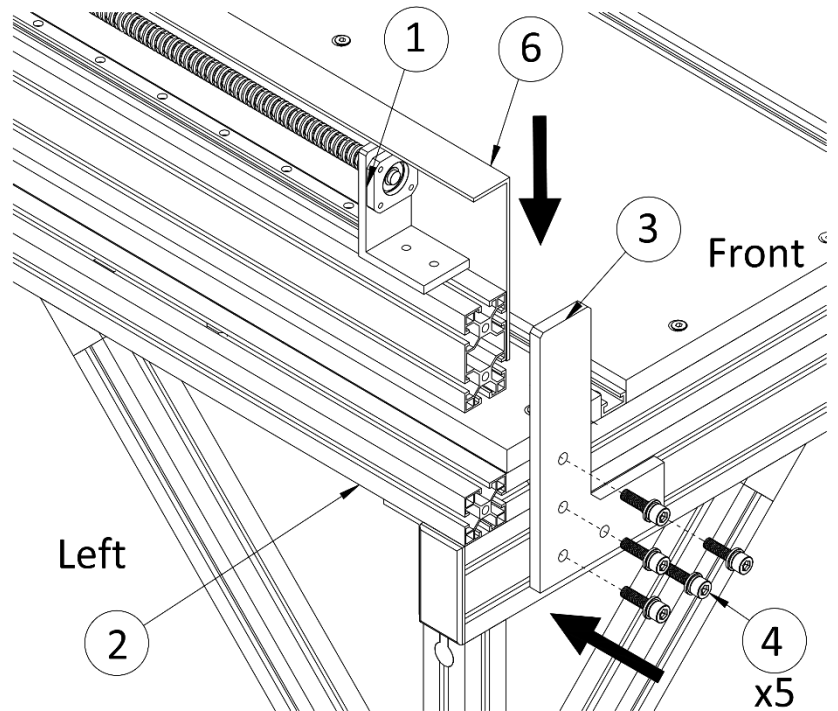

Key No.	Part Number	Model	Quantity
1	YL49, YR49, YL43, YR43	Y-L Assembly, Y-R Assembly	1
3	Y5	Front Y-Joining Plate	2
4	FG825	M8 x 25 Black Socket Head Screw with Lock Washer and Flat Washer	20
5	Y4	Back Y-Joining Plate	2

## 2. ASSEMBLING BRACKETS

- Assemble left and right **XY-Joining Plates** ① ② to two **X-Back Plates** ③ using ten **M6x20 Black Socket Head Screw Sets** ④ with lock washers and flat washers.
- Fully tighten these screws.

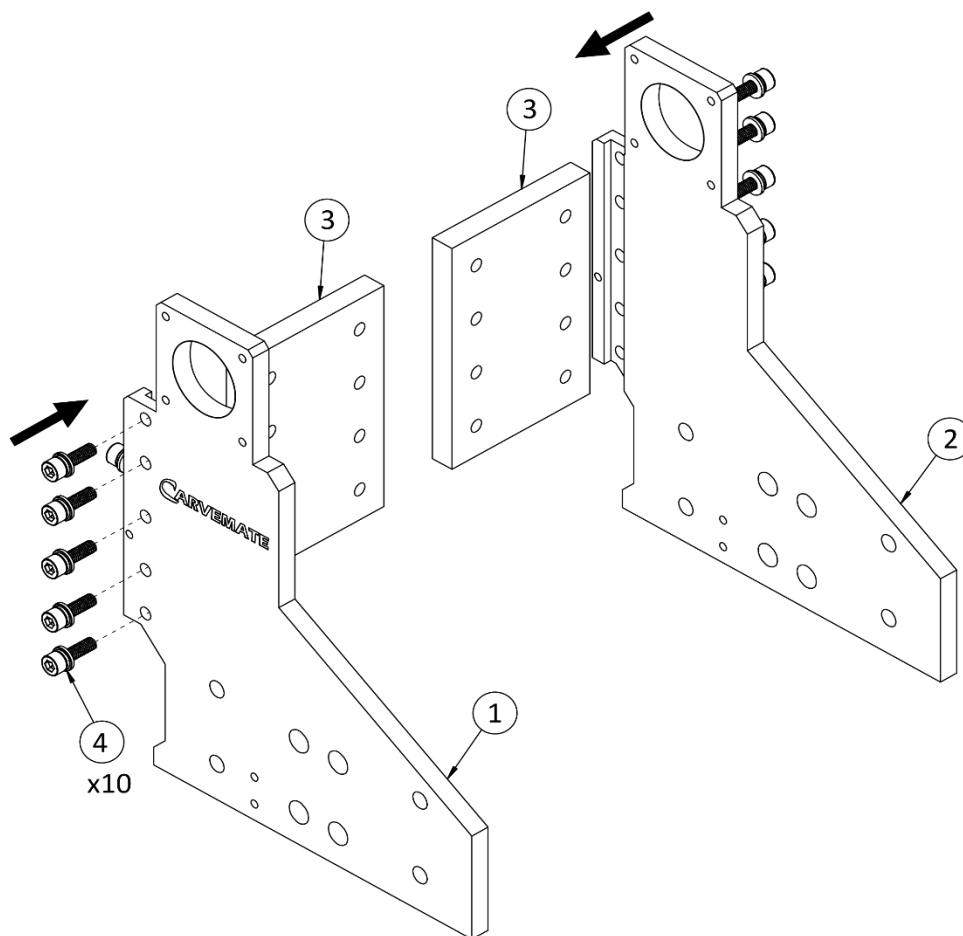

Key No.	Part Number	Model	Quantity
1	XYL	Left XY-Joining Plate	1
2	XYP	Right XY-Joining Plate	1
3	X7	X-Back Plate	2
4	FB620	M6x20 Black Socket Head Screw with Lock Washer and Flat Washer	10

## 3. INSTALLING JOINING BRACKETS TO X-ASSEMBLY

- Place the **X-Assembly** ① on the table with its back facing up and the ball screw toward the operator.
- Insert eight **30M6 T-Nuts** ⑤ into the back slots from the left end.
- Attach the assembled left **X-Back Plate** ② to the left end of the **X-Assembly** ① by threading eight **M6x22 Black Socket Head Screw Sets** ④ with lock washers and flat washers into the eight **30m6 T-Nuts** ⑤, keeping the **X-Back Plate** ② secured and horizontally adjustable on the aluminum extrusion.
- Slide a **Shaft Coupling** ⑥ onto the end of the ball screw ① to an 11 mm depth.
- Tighten the set screw on the **shaft coupling** ⑥ to secure it to the ball screw.
- Insert a **Motor** ⑦ (without brake) into the **Shaft Coupling** ⑦ until it contacts the **XY-Joining Plate** ③.
- Tighten the set screw on the **Shaft Coupling** ⑥ to secure the **Motor** ⑦ in place.
- Gently tap the **X-Back Plate** ② back and forth with a rubber mallet (not included) to align its four threaded holes with the motor's mounting holes while keeping the **X-Back Plate** ② parallel to the aluminum extrusion.
- Secure the **Motor** ⑦ to the **XY-Joining Plate** ③ by hand-tightening four **M5x16 Galvanized Socket Head Screw Sets** ⑧.
- Fully tighten the eight **M6x22 Black Socket Head Screw Sets** ④.
- Remove the **Motor** ⑦ and **Shaft Coupling** ⑥.

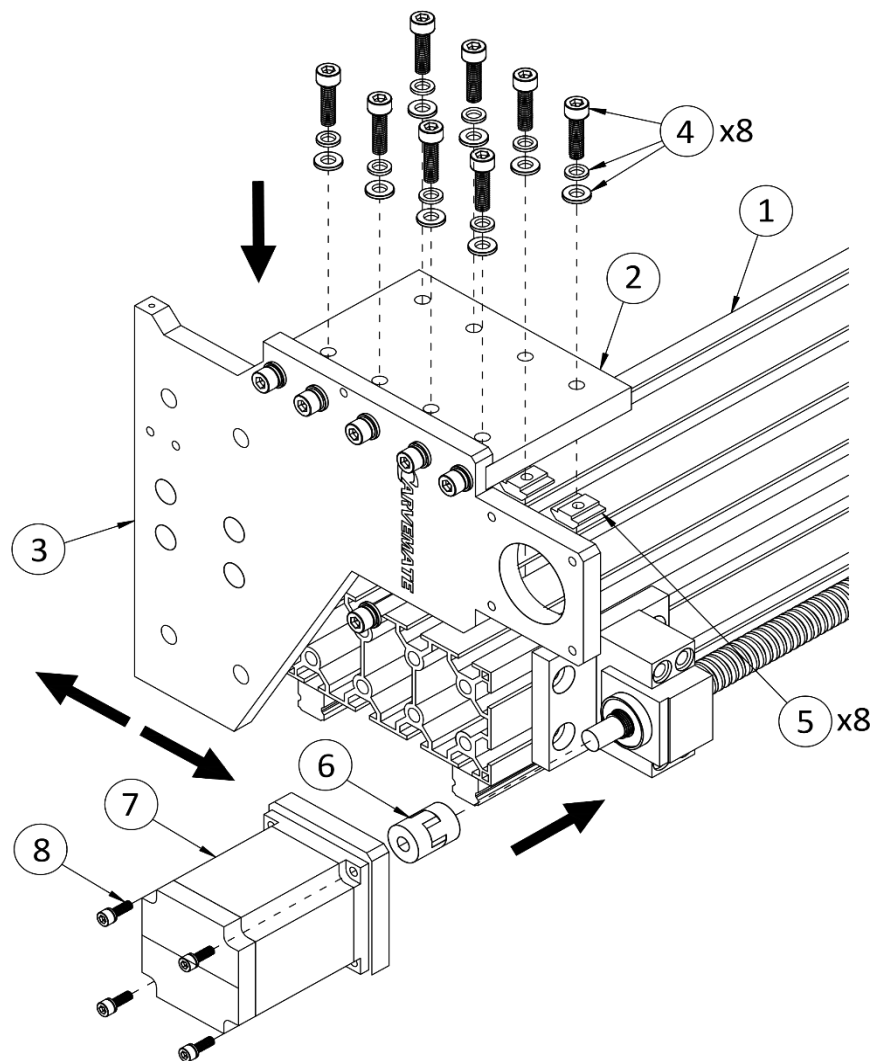

Key No.	Part Number	Model	Quantity
1	X49	X-Assembly	1
2	X7	X-Back Plate	1
3	XYL	Left XY-Joining Plate	1
4	FB622	M6x22 Black Socket Head Screw with Lock Washer and Flat Washer	8
5	NS36	30M6 T-Nut	8
6	M4	Shaft Coupling	1
7	M1	Motor	1
8	FG516	M5x16 Galvanized Socket Head Screw with Lock Washer	4

## 4. ASSEMBLING X-ASSEMBLY TO Y-AXIS

### ⚠ CAUTION:

THE X-ASSEMBLY IS HEAVY AND COULD TIP OFF THE Y-ASSEMBLIES DURING INSTALLATION. USE EXTREME CARE TO PREVENT IT FROM FALLING.

- Slide both **L-Shaped Carriages** (5) on the left and right Y-Assemblies forward to the front limit of the machine.
- Carefully place the **X-Assembly** (1) onto the **L-Shaped Carriages** (5) on both Y-Assemblies, ensuring the linear rails face forward and the left **XY-Joining Plate** (2) touches the left carriage (5).
- Keep the **X-Assembly** (1) resting firmly on the **L-Shaped Carriages** (5) throughout the process.
- Insert eight **30M6 T-Nuts** (8) into the back slots of the **X-Assembly** (1) from the right end.
- Attach the assembled right **X-Back Plate** (6) to the right end of the **X-Assembly** (1) until it contacts the right **L-shaped Carriage** (5).
- Secure the right **X-back plate** (6) to the **X-Assembly** (1) by threading eight **M6x22 Black Socket Head Screw Sets** (7) with lock washers and flat washers into the **30M6 T-Nuts** (8), tightening them just enough to hold the plate while allowing it to shift on the aluminum extrusion.
- Adjust the **X-Assembly** (1) until the left **XY-Joining Plate** (2) contacts the left **L-shaped Carriage** (5), while maintaining a consistent about 2 mm offset (4) between the back surfaces of the left and right **XY-Joining Plate** (2)(6) and the **L-shaped Carriages** (5).

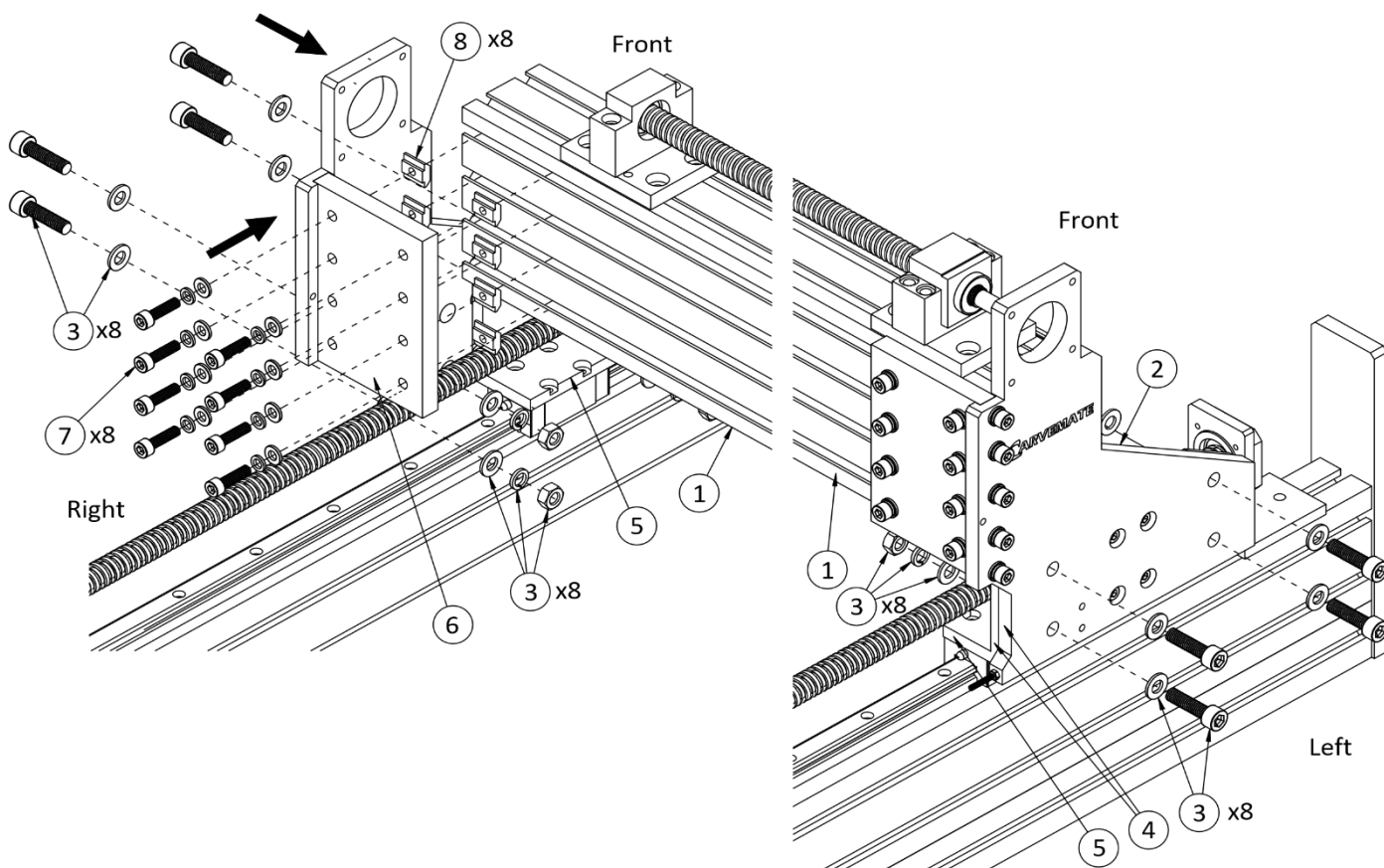

Key No	Part Number	Model	Quantity
1		X-Assembly	1
2		Assembled X-Back Plate and XY-Joining Plate, Left	1
3	FB830	M8x30 Black Socket Head Screw with Lock Washer and Flat Washer x 2 and Nut	8
5		L-Shaped Carriage	1
6		Assembled X-Back Plate and XY-Joining Plate, Right	1
7	FB622	M6x22 Black Socket Head Screw with Lock Washer and Flat Washer	8
8	NS36	30M6 T-Nut	8

- Gently tap the right **XY-Joining Plate** ⑥ with a rubber mallet until it contacts the right **L-shaped Carriage** ⑤.
- Check for gaps between the left and right **XY-Joining Plate** ②⑥ and the **L-shaped carriages** ⑤, filling any gaps with metal shims or folded aluminum foil.
- Secure the left **XY-Joining Plate** ② to the left Y-assembly using four **M8x30 Black Socket Head Screws** ③ with Lock Washers, Flat Washers, and Nuts. Fully tighten the screws.
- Secure the right **XY-Joining Plate** ⑥ to the **L-shaped carriage** ⑤ using four **M8x30 Black Socket Head Screw Sets** ③ with lock washers, flat washers, and nuts.
- Hand-tighten the two screws on the side with no Gap, keeping the other two screws loose.

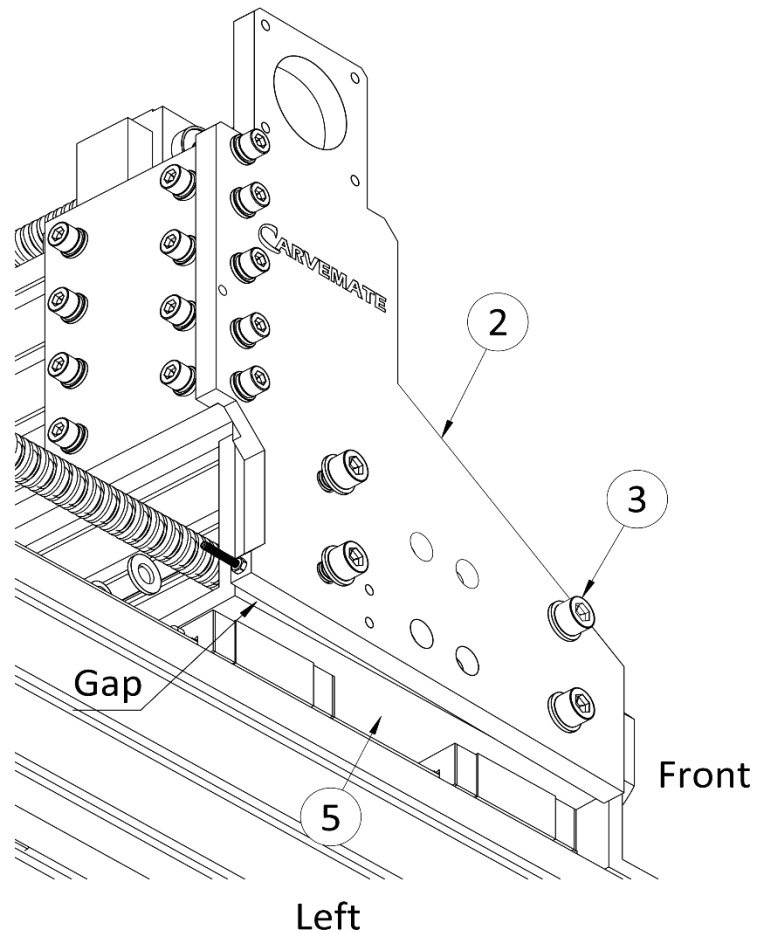
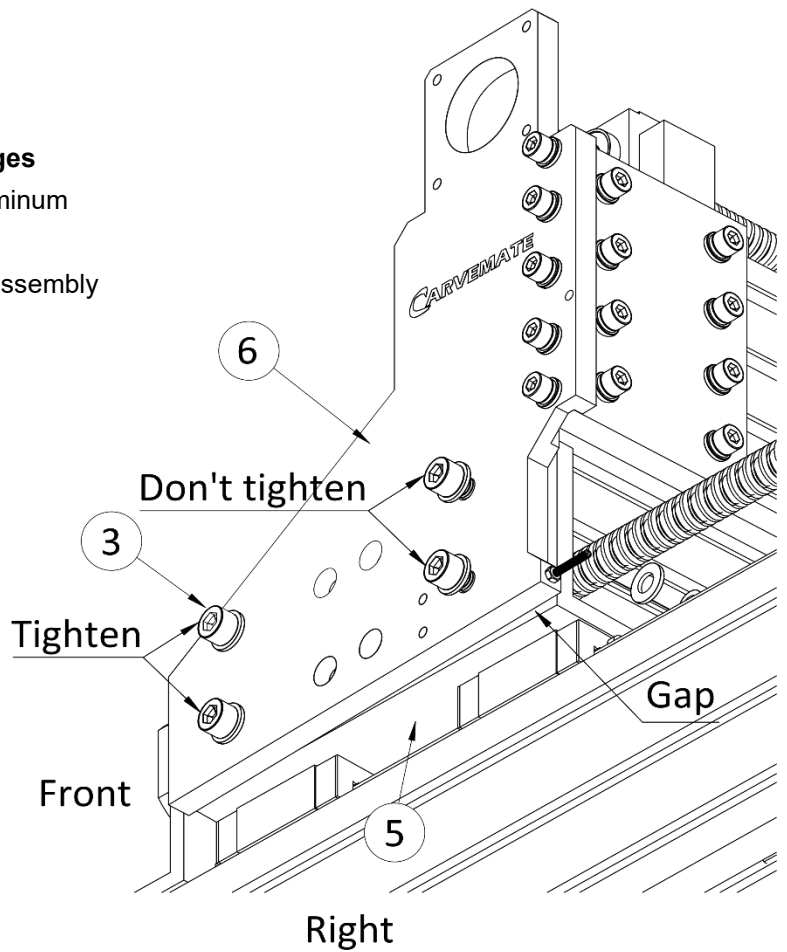

- Push the **X-Assembly** ① back and forth near the front of the machine to ensure smooth movement with minimal resistance.
- Push the **X-Assembly** ① toward the rear of the machine.
- Gently tap the end of the right Y-Assembly ⑨ with a rubber mallet (not included) to shift it left or right as needed. Loosen and retighten the two secured **M8x30 Screws** ③ on the **XY-Joining Plate** ⑥ during adjustment to maintain smooth motion.
- Recheck the gap between the right **XY-Joining Plate** ⑥ and the **L-shaped carriage** ⑤. Adjust or add shims if necessary.
- Fully tighten all four **M8x30 Black Socket Head Screw Sets** ③ to secure the right **XY-Joining Plate** ⑥.
- Slide a **Shaft Coupling** ⑫ onto the ball screw end of the right **Y-Assembly** ⑨ to a depth of 11 mm.
- **Tighten** the set screw on the **Shaft Coupling** ⑫.
- Insert a **Motor** ⑬ (without brake) into the **Shaft Coupling** ⑫ until it contacts the **Back Y-Joining Plate** ⑪.
- Tighten the set screw on the **Shaft Coupling** ⑫ to hold the **Motor** ⑬ in place.
- Gently tap the right **Back Y-Joining Plate** ⑪ with a rubber mallet (not included) to align its threaded holes with the motor's mounting holes. Use any M5 screw to verify alignment.
- Fully tighten all screws on the right **Back Y-Joining Plate** ⑪.
- Remove the motor and shaft coupling.
- Repeat the above steps for the left Y-Assembly.
- Slide the **X-Assembly** ① forward to the front of the machine. Recheck for smooth movement.
- Fully tighten all screws on the **Front Y-Joining Plates** ⑩ to complete the X-Assembly installation.

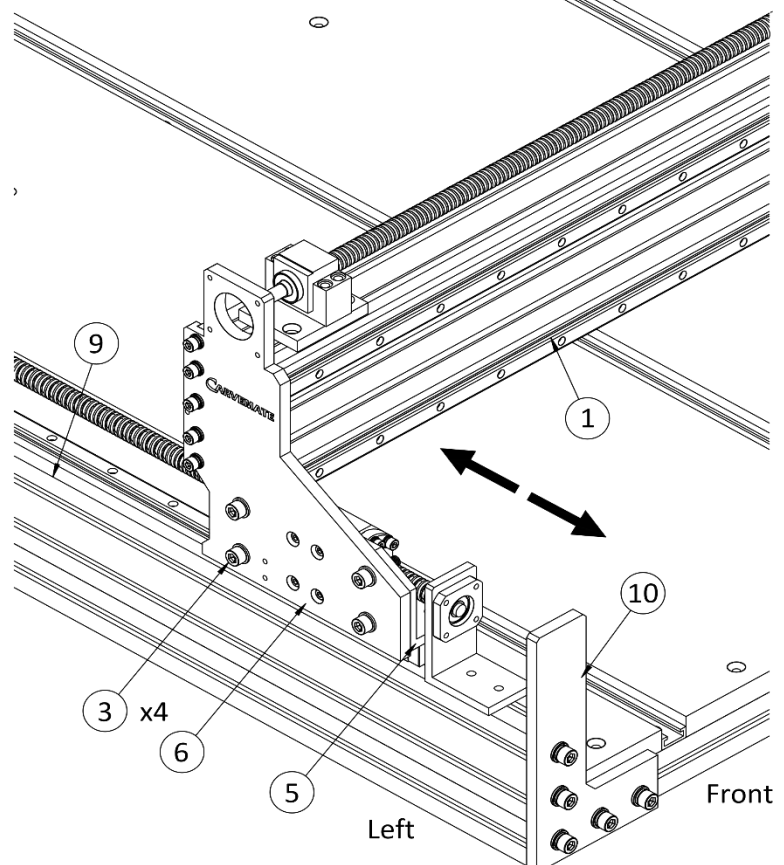
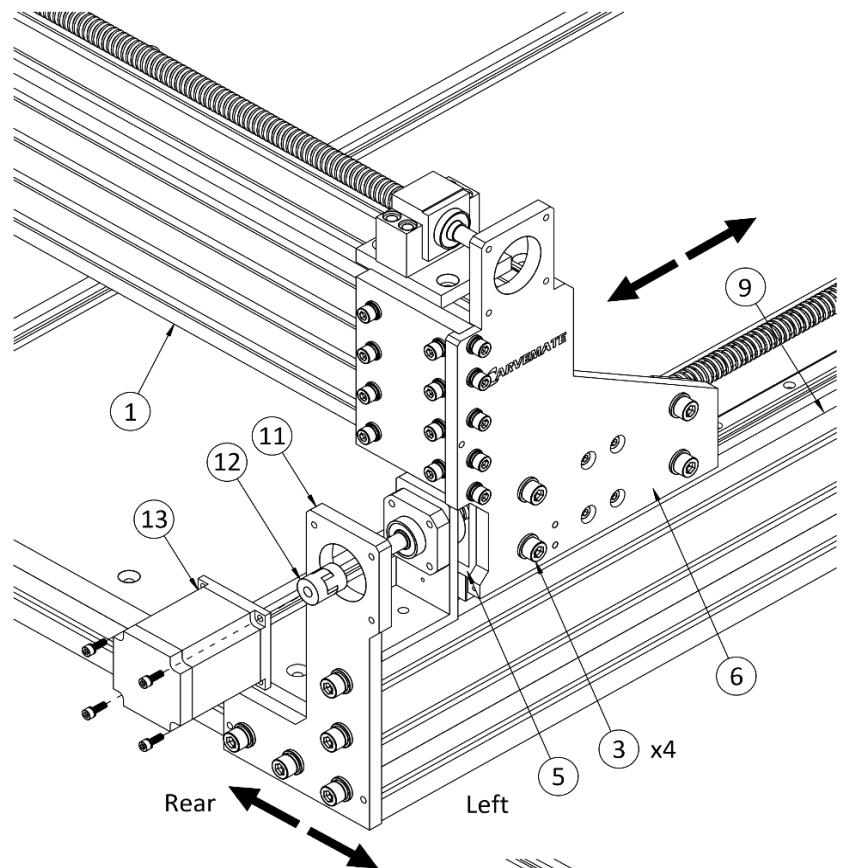

## 5. ASSEMBLING Z-ASSEMBLY

- Attach the **Z-Assembly** ① to the **Carriage Plate** ② on the **X-Assembly** using four **M6x16 Black Socket Head Screw sets** ④ with lock washers and flat washers. To access the four mounting holes for the **M6x16 screws** on the back plate ① of the **Z-Assembly**, slide the **Carriage Plate** ③ on the **Z-Assembly** up and down as needed.
- Hand-tighten four **M6x16 Black Socket Head Screw sets** ④ just enough to secure the plates while allowing them to move freely.

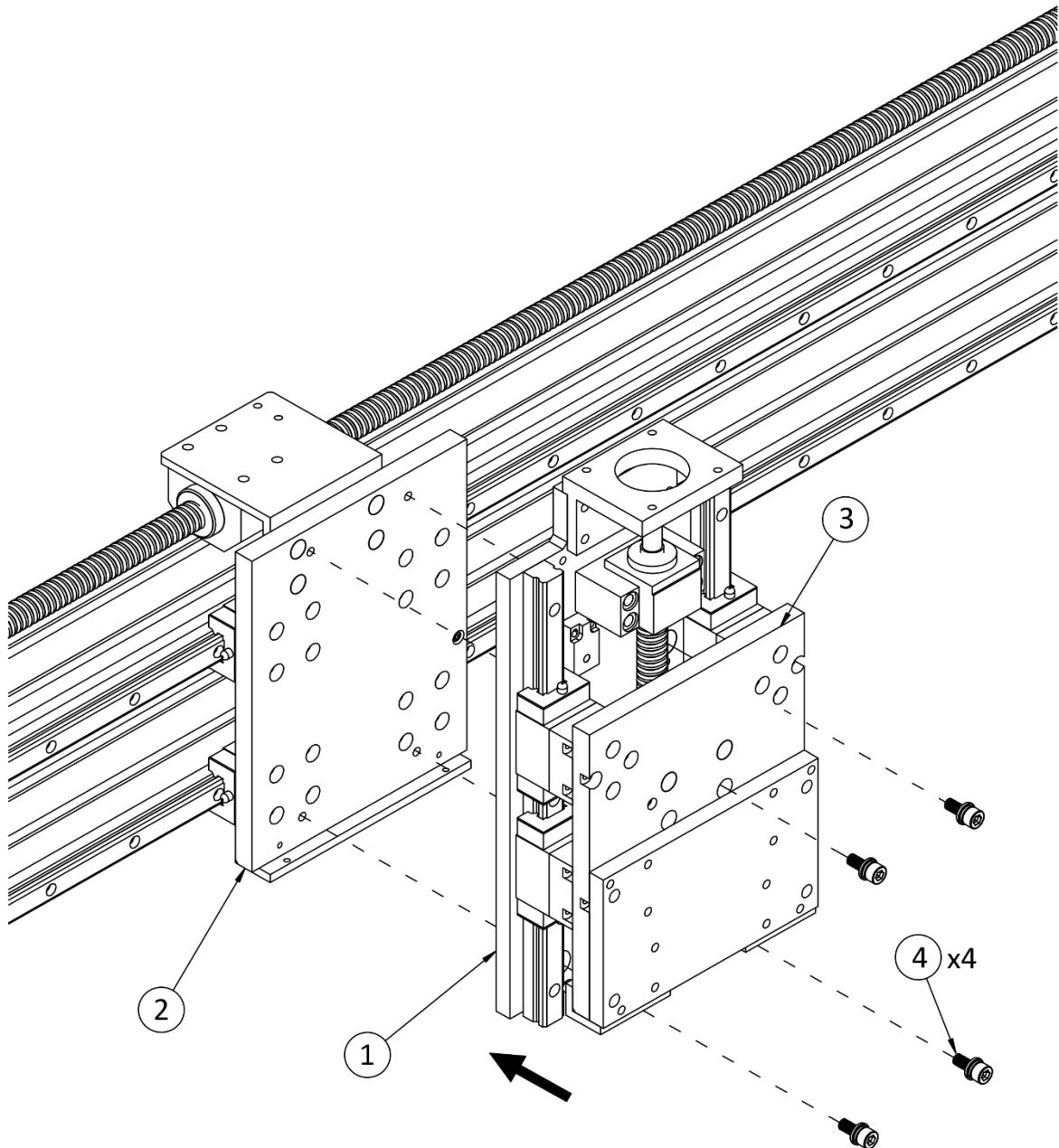

Key No	Part Number	Model	Quantity
1	Z49	Z-Assembly	1
4	FB616	M6x16 Black Socket Head Screw with Lock Washer, Flat Washer	4

## 1. SQUARING Z-ASSEMBLY IN X-DIRECTION

- The carriage plates at the front of the **Z-Assembly** are not shown in the diagrams to ensure a clearer view.
- Square the **Z-Assembly's** linear rails perpendicular to the work surface to ensure spindle travels vertically in both X and Y directions. Perform this squaring procedure as needed for routine alignment or service.
- Move Z-Assembly to the center of the work surface. Lower the linear blocks ② by turning the ball screws.
- Place a 250 mm (minimum) **Engineer's Square** ① (not included) on the work surface and align it to the left side ② of the two linear blocks to check for 90° alignment.
- Adjust one of the **Set Screws** ③ at the bottom of the **L-Shaped Bracket** ④ to eliminate the gap between the **Square** ① and linear blocks. Only adjust one **Set Screw** ③ to ensure at least one side of the **Z-Assembly** remains firmly in contact with the **L-Shaped Bracket** ④.

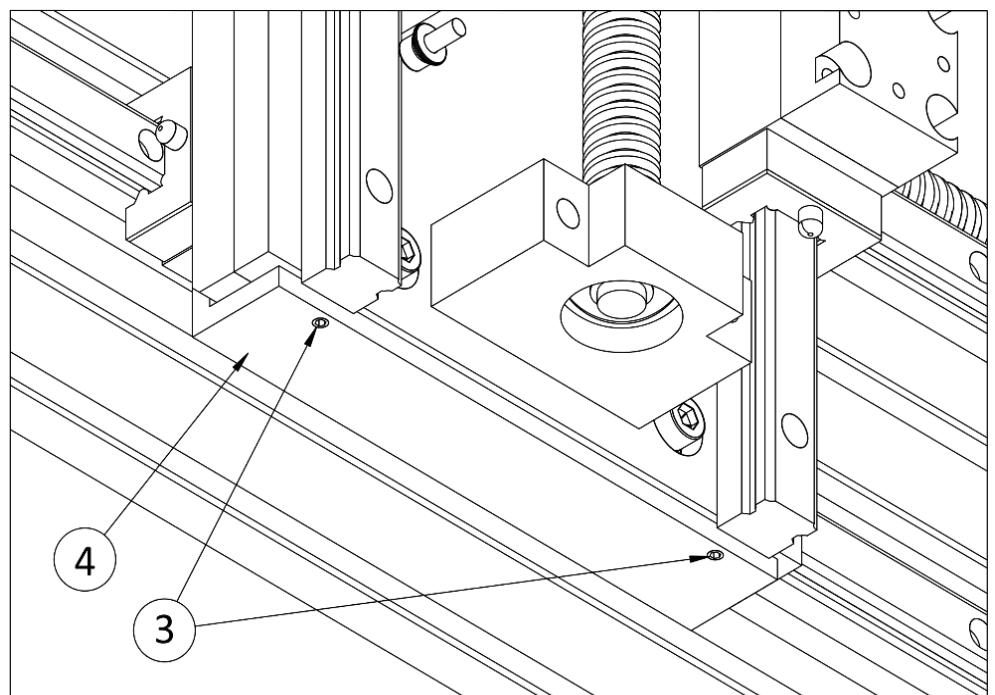
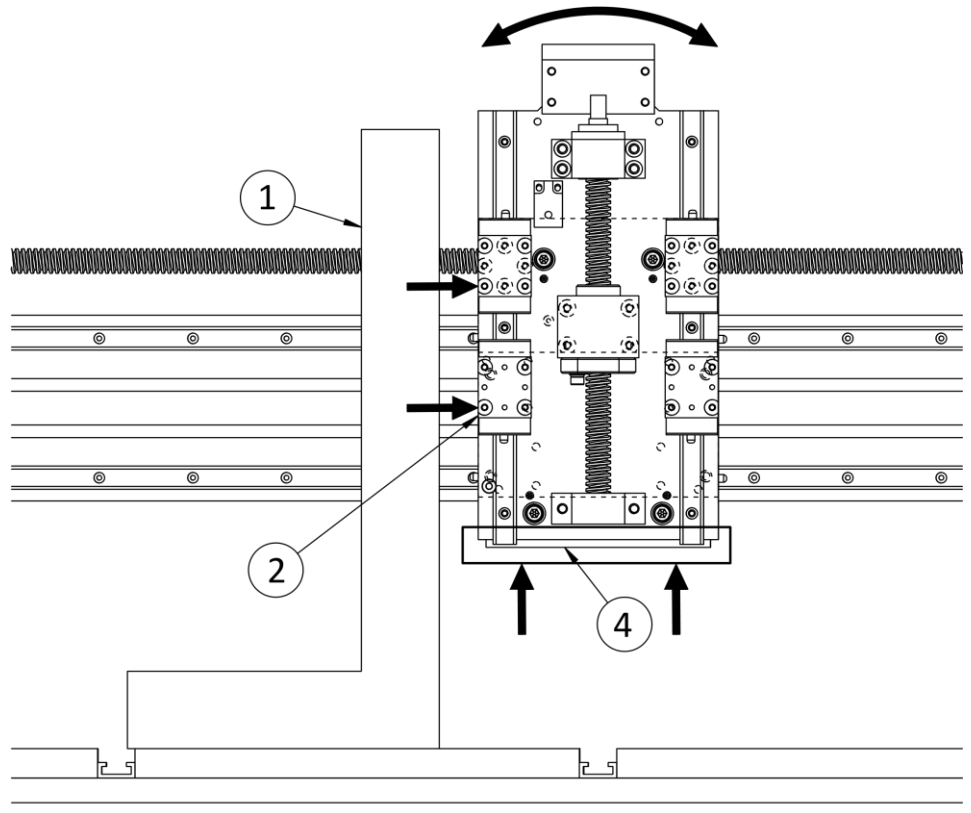

## 2. SQUARING Z-ASSEMBLY IN Y-DIRECTION

- The **Carriage Plates** ② at the front of the Z-Assembly are not shown in the diagrams to ensure a clearer view.
- Y direction alignment relies on four **M6x16 screws** ④ and four adjacent **Set Screws** on the **Z-Assembly back plate** ⑤. These can be accessed by sliding the **Carriage Plate** ② up and down.
- Place a 250 mm (minimum) **Engineer's Square** (not included) on the work surface and align it to the front of the **Carriage Plate** ② to check for 90° alignment.
- To eliminate the gap between the **Square** ① and the upper side of **Carriage Plate** ②, loosen the top two **M6x16 screws** ④, thread in the two adjacent **Set Screws** ③ equally, then insert **Metal Shims** ⑦ or folded aluminum foil to fill the gap between the **Z-Assembly Back Plate** ⑤ and **X-Assembly Carriage Plate** ⑥.
- Retighten the two **M6x16 screws** ④.
- To eliminate the gap between the square and the lower side of **Carriage Plate** ②, repeat the same steps with the bottom two **M6x16 Screws** ④ and their adjacent **Set Screws** ③.

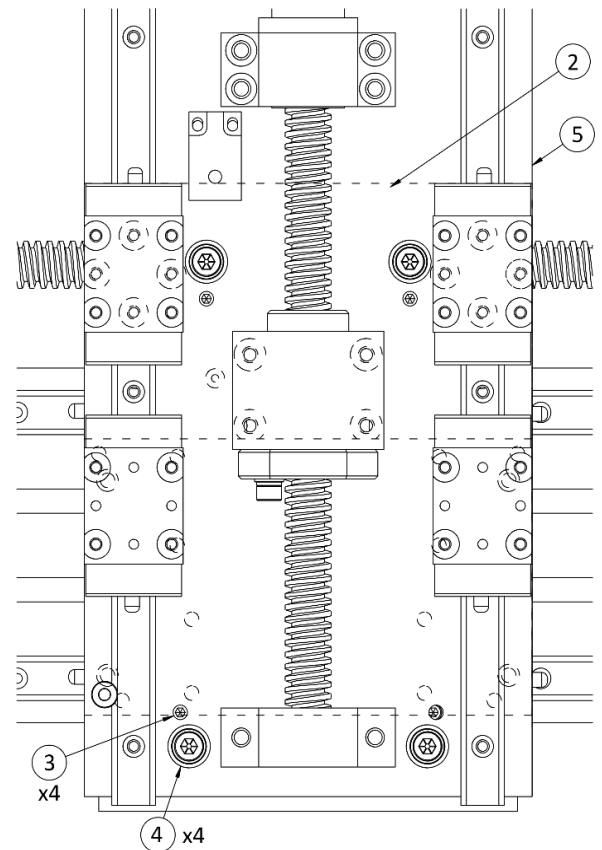
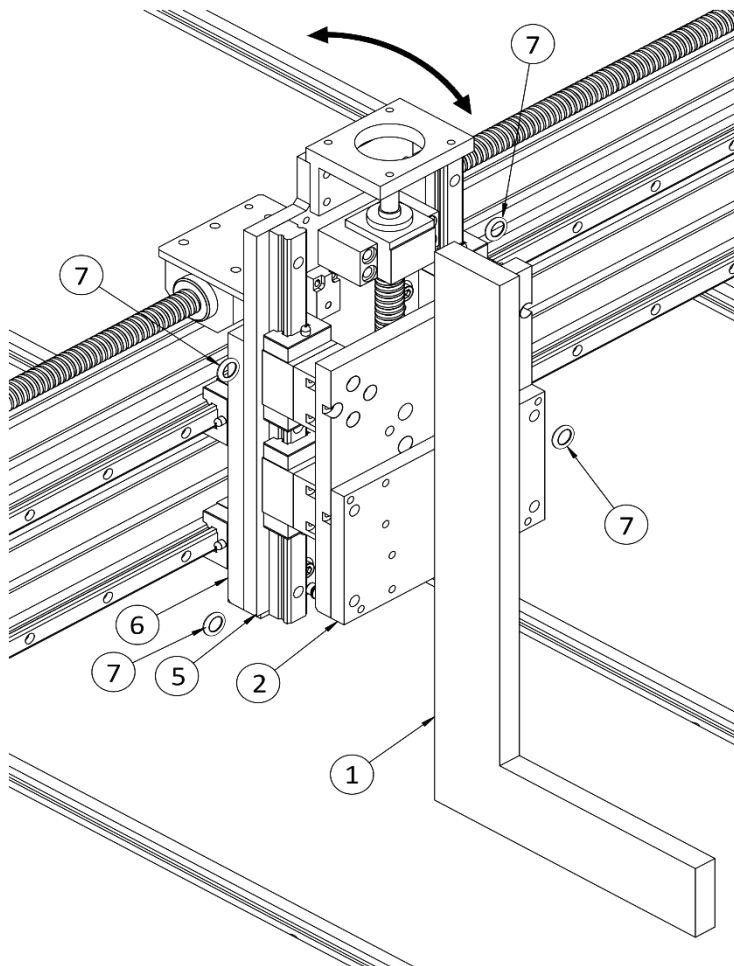

# DRAG CHAIN

# PARTS LIST

## 1. PARTS INCLUDED

	ST4949B, F	ST4933B, F	
<b>Model</b>	Y-Chain Mount	Y-Chain Mount	X-Chain Mount
<b>Part Number</b>	AL5Y4	AL5Y3	AL5X
<b>Quantity</b>	700 mm	480 mm	1300 mm
	1	1	1

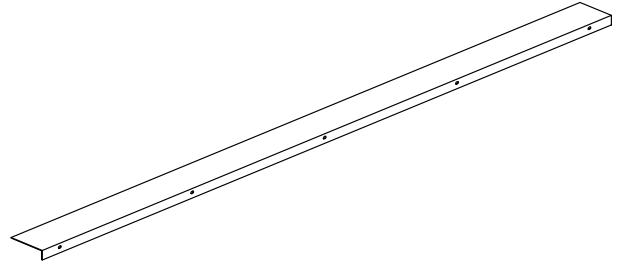
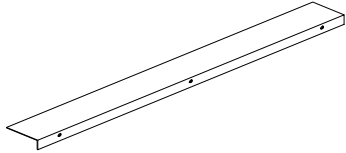

	Y-Chain Mount	Y-Chain Mount	X-Chain Mount
<b>Model</b>	Y-Chain Mount	Y-Chain Mount	X-Chain Mount
<b>Part Number</b>	DCY4	DCY3	DCX
<b>Quantity</b>	1 (40 Links)	1 (29 Links)	1 (70 Links)

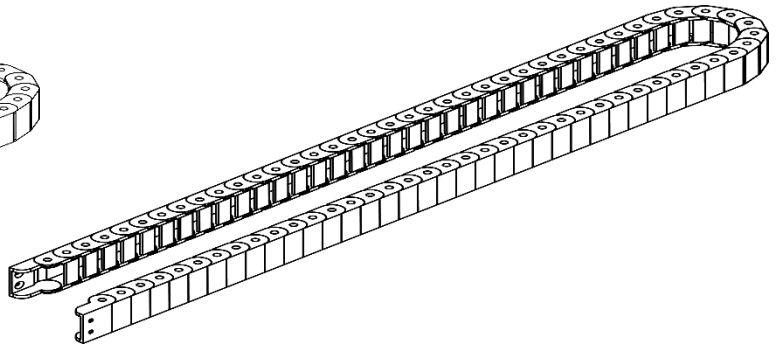
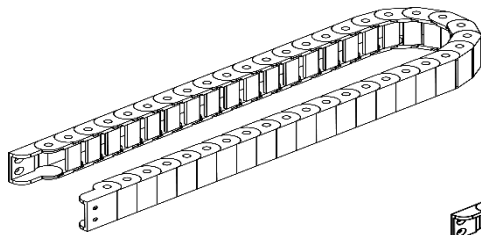

	X-Chain Bracket	Y-Chain Bracket	30M6 Roll-in T-nut	M4x14 Stainless Steel Flat Head Screw with Flat Washer, Lock Washer and Nut
<b>Model</b>	X-Chain Bracket	Y-Chain Bracket	30M6 Roll-in T-nut	M4x14 Stainless Steel Flat Head Screw with Flat Washer, Lock Washer and Nut
<b>Part Number</b>	X4	X5	NR36	FG414
<b>Quantity</b>	1	1	8	8

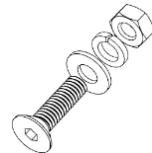
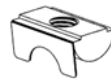
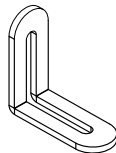
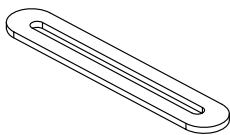

	M5x10 Black Socket Head Screw with Lock Washer and Flat Washer	M6x12 Galvanized Pan Head Screw with Flat Washer and Lock Washer
<b>Model</b>	M5x10 Black Socket Head Screw with Lock Washer and Flat Washer	M6x12 Galvanized Pan Head Screw with Flat Washer and Lock Washer
<b>Part Number</b>	FB510	FG612
<b>Quantity</b>	4	8



# DRAG CHAIN

# ASSEMBLY

## 1. ASSEMBLING DRAG CHAIN MOUNTS

- Insert three **30M6 Roll-In T-Nuts** ① into the left slot ② of the left Y-Beam of the base with an Allen key, as shown in the diagram.
- Insert five **30M6 Roll-In T-Nuts** ① into the second back slot ② of the X-Assembly.

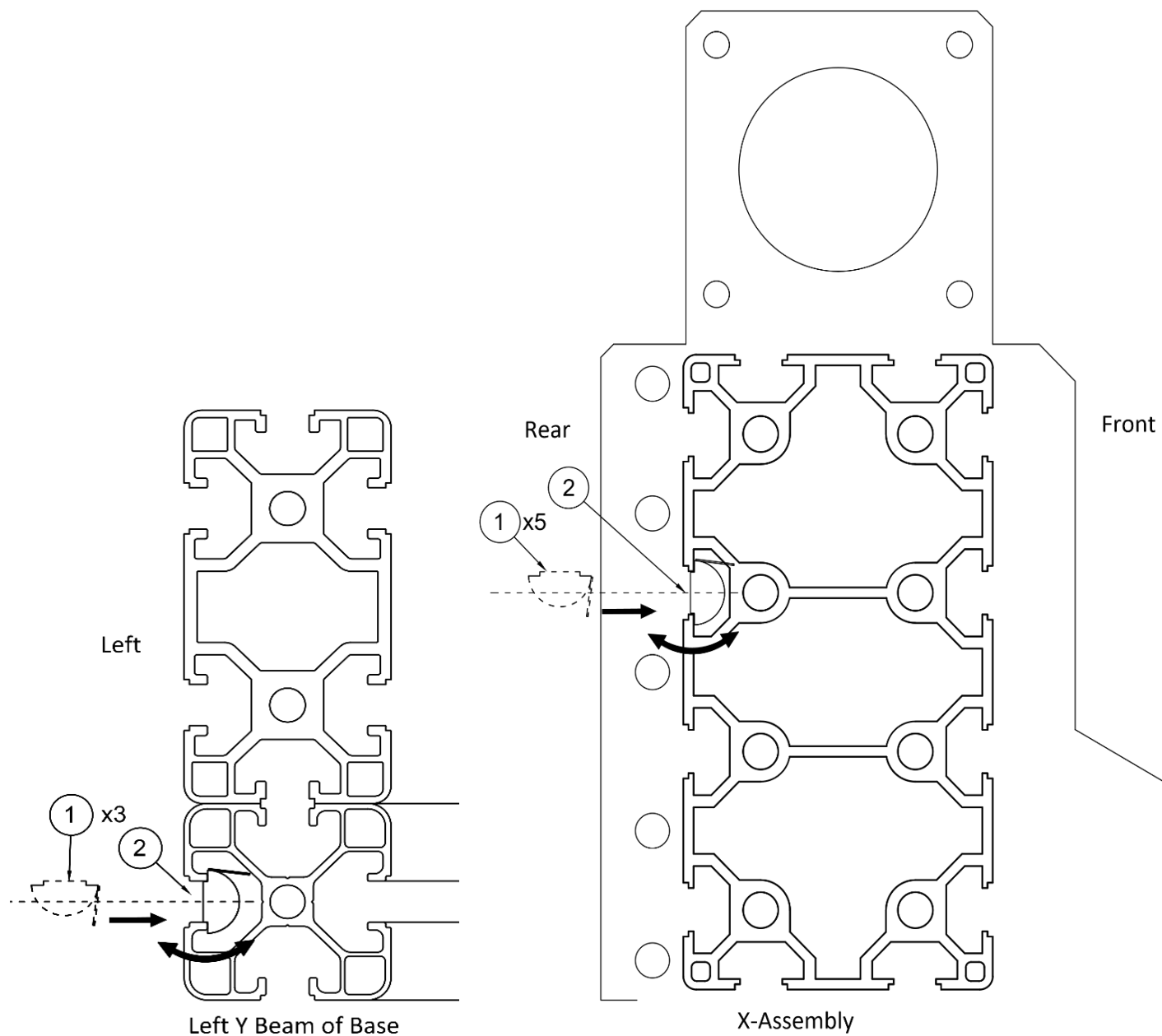
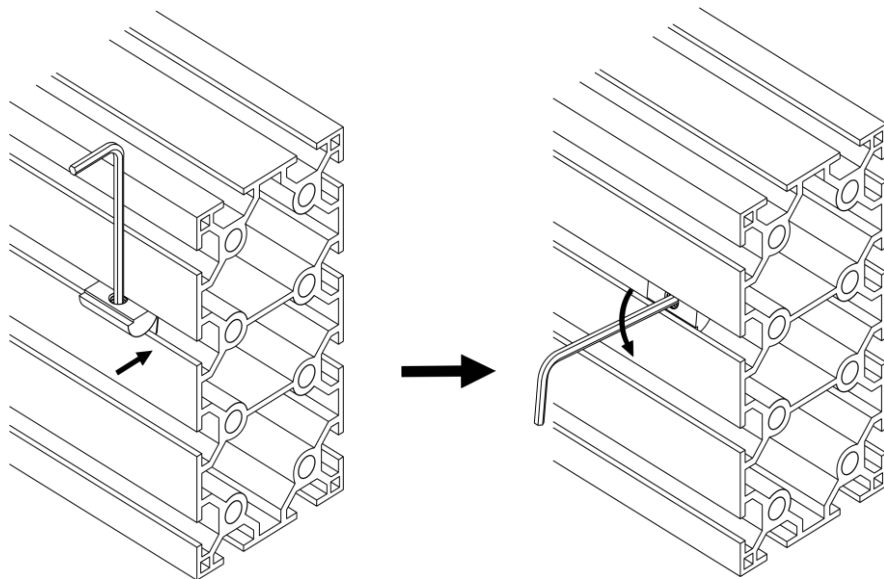

# DRAG CHAIN

# ASSEMBLY

- Attach the **Y-Chain Mount** ① to the left slot ③ of the left Y-Beam of the base by threading three **M6x12 Galvanized Pan Head Screw Sets** ② into the three **30M6 Roll-In T-Nuts** already installed in the slot.
- Slide the **Y-Chain Mount** ① until its front edge is 180 mm from the front of Y-beam extrusion.
- Attach the **X-Chain Mount** ④ to the second back slot ⑤ of the X-Assembly by threading five **M6x12 Galvanized Pan Head Screw Sets** ② into the five **30M6 Roll-In T-Nuts** already installed in the slot.
- Keep the **X-Chain Mount** ① in the middle of the X-Assembly.
- Fully tighten all screws.

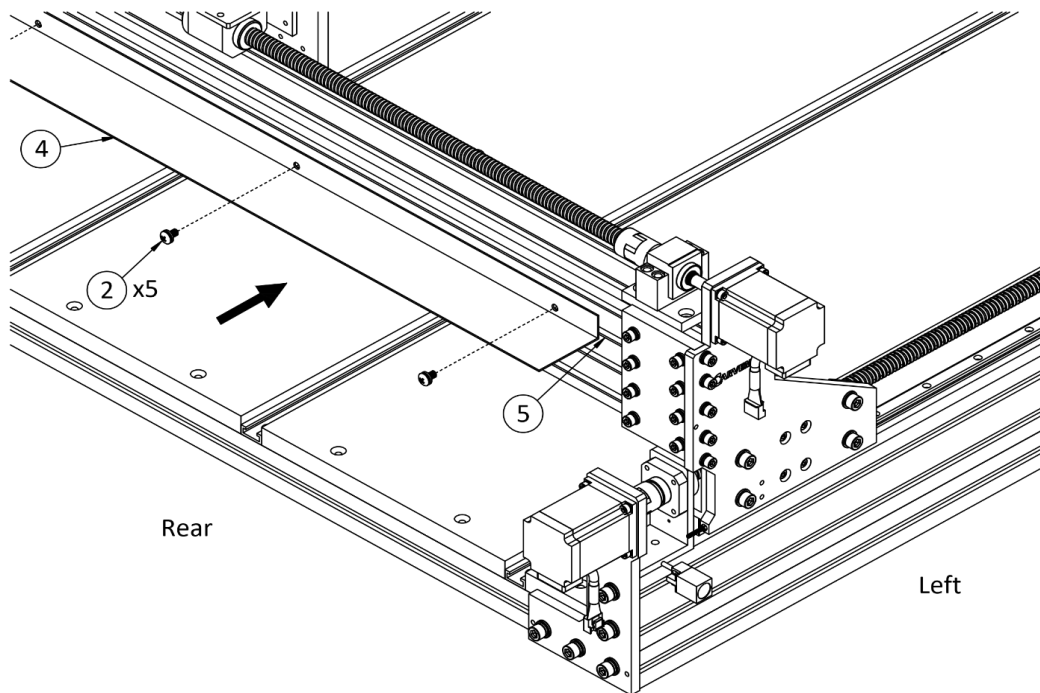
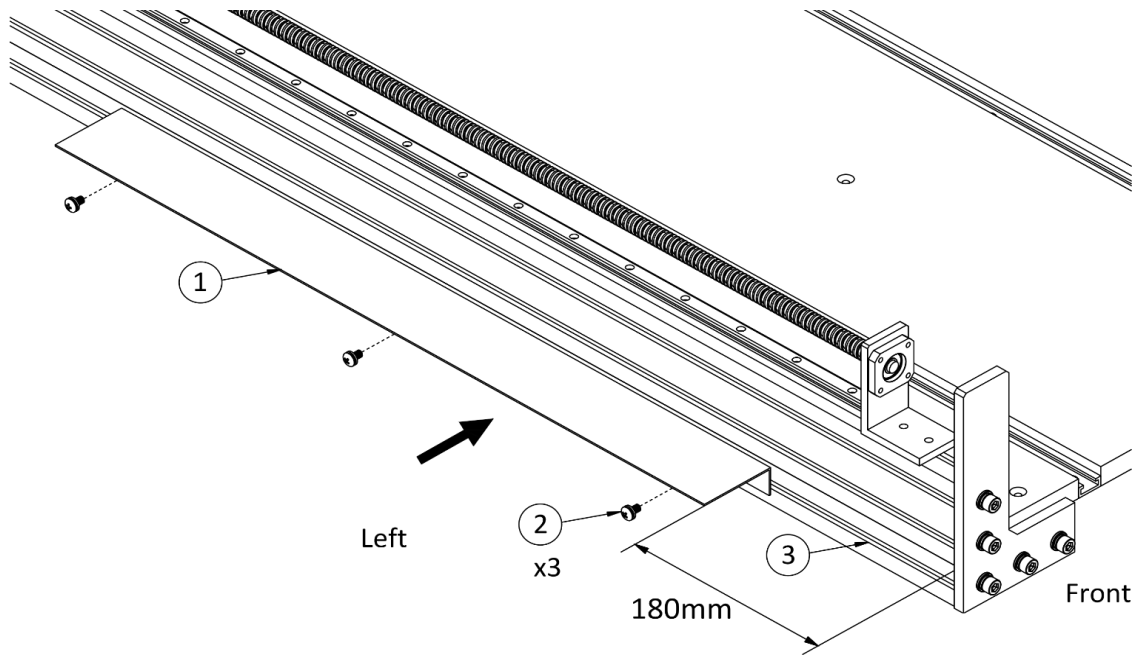

Key No	Part Number	Model	Quantity
1	AL5YL4, AL5Y3	Y-Chain Mount	1
2	FG612	M6x12 Galvanized Pan Head Screw with Flat Washer and Lock Washer	8
4	AL5X	X-Chain Mount	1

# DRAG CHAIN

# ASSEMBLY

## 2. ASSEMBLING DRAG CHAIN BRACKETS

- Attach the **Y-Chain Bracket** (4) to the left **XY-Joining Plate** (5) using two **M5x10 Black Socket Head Screw Sets** (2) with lock washers and flat washers.
- Adjust the **Y-Chain Bracket** (4) until its Bottom side is 6 mm lower than the bottom of the **XY-Joining Plate** (5).
- Hand-tighten the screws (2).
- Attach the **X-Chain Bracket** (1) to the bracket (3) using two **M5x10 Black Socket Head Screw Sets** (2) with lock washers and flat washers.
- Adjust the **X-Chain Bracket** (1) until it extends 76 mm beyond the bracket (3).
- Hand-tighten the screws (2).

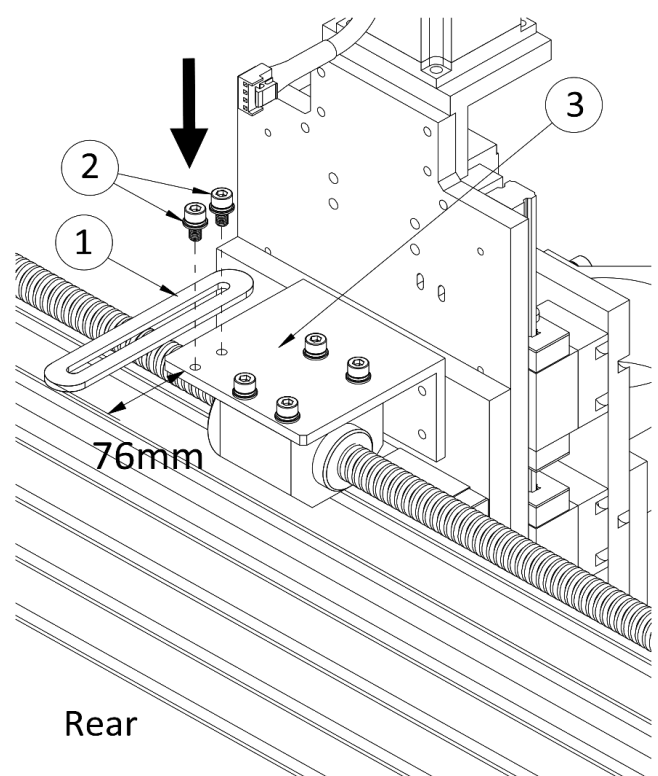
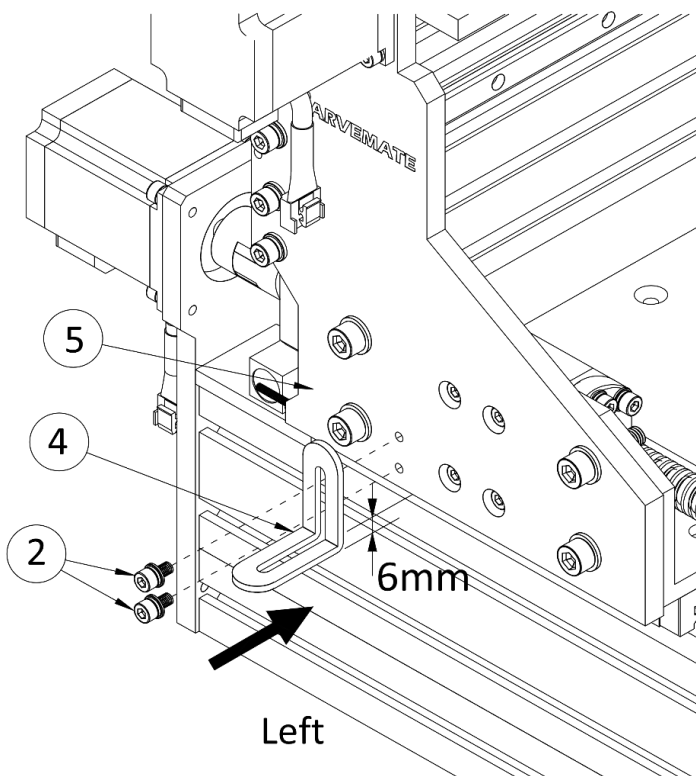

Key No	Part Number	Model	Quantity
1	X4	X-Chain Bracket	1
2	FB510	M5x10 Black Socket Head Screw with Lock Washer and Flat Washer	4
4	X5	Y-Chain Bracket	1

# DRAG CHAIN

# ASSEMBLY

## 3. ASSEMBLING Y DRAG CHAINS

- Install the **Y-Chain** ① by securing its two end connectors ② to the **Y-Chain Mount** ④ and the **Y-Chain Bracket** ⑤ using four **M4x14 Flat Head Screw Sets** ③ with flat Washers, lock Washers and nuts.
- Adjust the end connectors' positions to keep the entire drag chain untwisted.
- Fully tighten all screws.

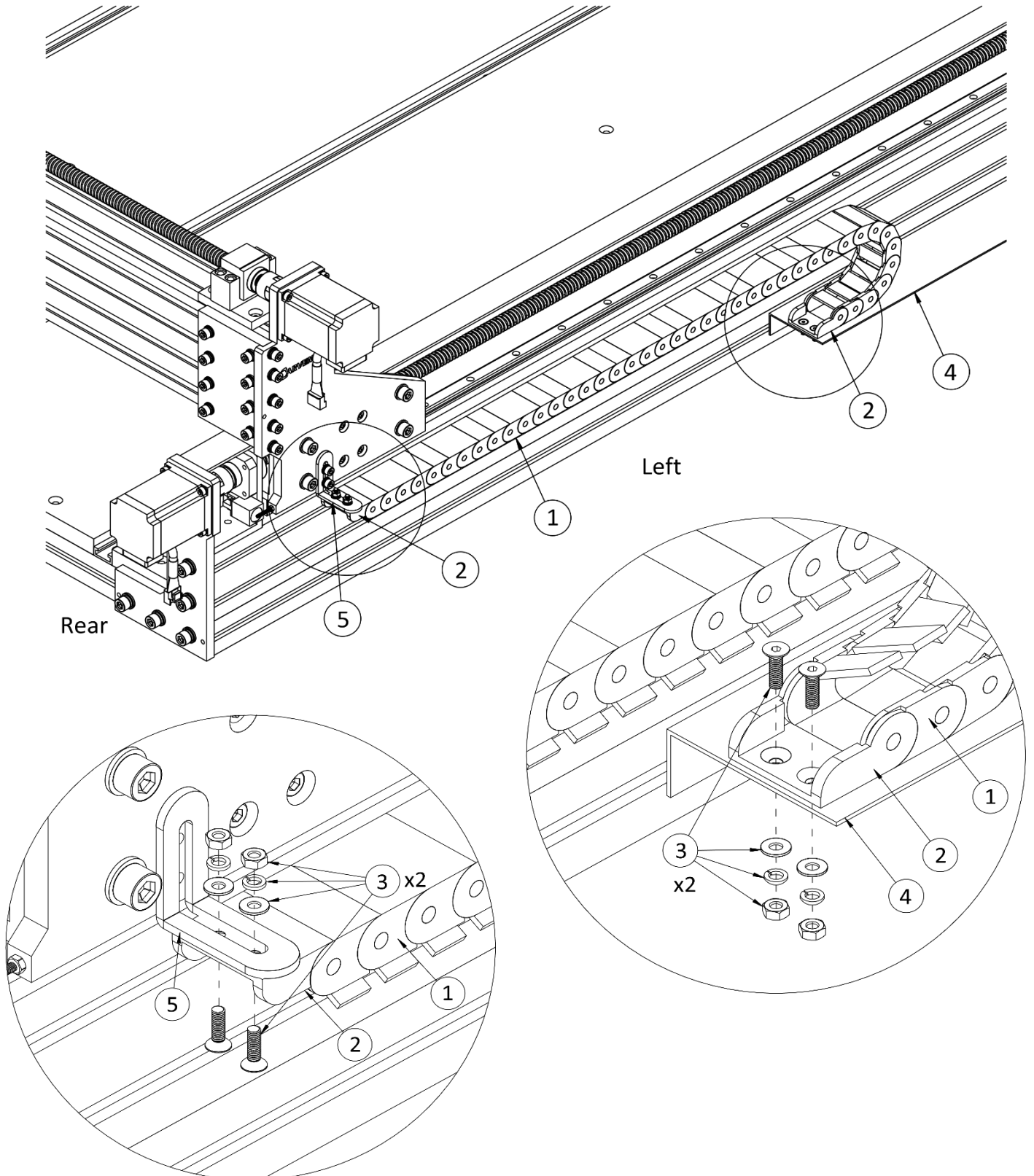

# DRAG CHAIN

# ASSEMBLY

## 4. ASSEMBLING X DRAG CHAINS

- Install the **X-Chain** ① by securing its two end connectors ② to the **X-Chain Mount** ④ and the **X-Chain Bracket** ⑤ using four **M4x14 Flat Head Screw Sets** ③ with flat Washers, lock Washers and nuts.
- Adjust the end connectors' positions to keep the entire drag chain untwisted and clear of screw heads at the rear right of the X-Assembly.
- Fully tighten all screws.

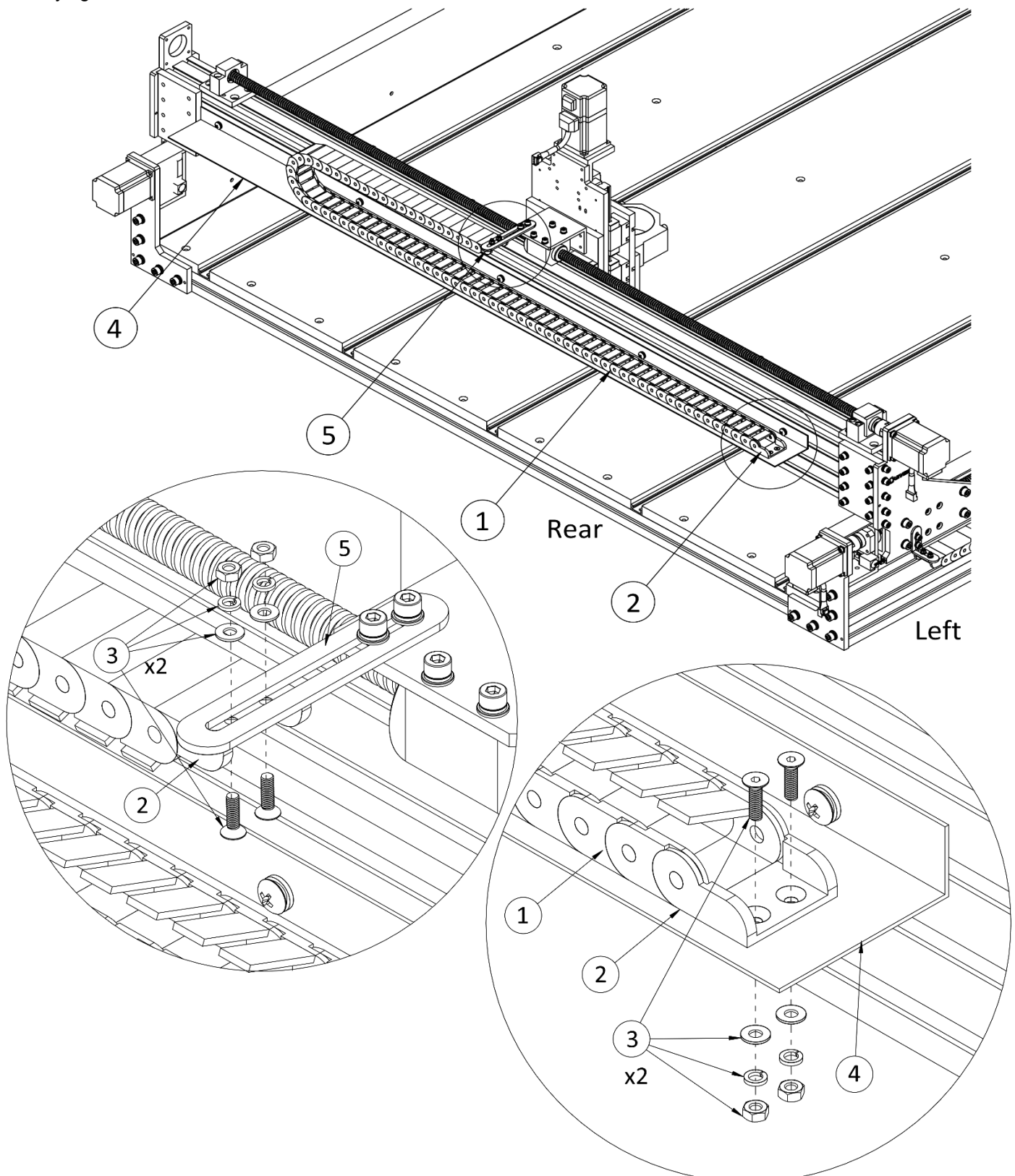

# ELECTRONICS

# PARTS LIST

## 1. PARTS INCLUDED

<b>Model</b>	Motor with Brake	Motor	Shaft Coupling	Y Limit Sensor
<b>Part Number</b>	M2	M1	M4	SW18
<b>Quantity</b>	1	3	4	2

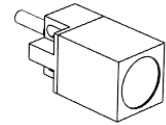
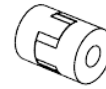
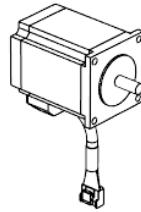
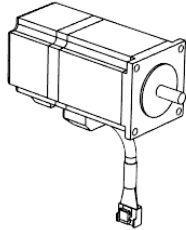

<b>Model</b>	VFD Enclosure	Spindle Mount 80 mm	Spindle Mount 65 mm
<b>Part Number</b>	VB15, VB22	Z80	Z65
<b>Quantity</b>	1	1	1

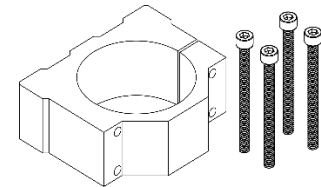
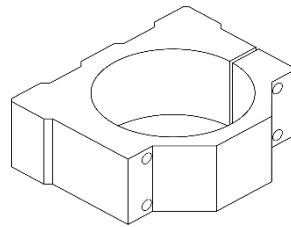
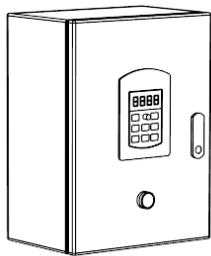

<b>Model</b>	Motor Cable	Sensor Cable	Brake Cable	Spindle
<b>Part Number</b>	CB8X, Y, A, Z	CB9X, Y, A, Z	CB10	S15, S22
<b>Quantity</b>	4	4	1	1

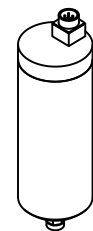
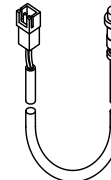
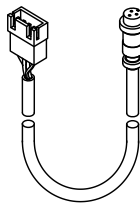
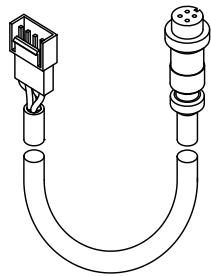

<b>Model</b>	30M6 Roll-in T-nut	M5x16 Galvanized Socket Head Screw with Lock Washer	M6x20 Galvanized Socket Head Screw with Lock Washer and Flat Washer
<b>Part Number</b>	NR36	FG516	FG620B
<b>Quantity</b>	3	16	3

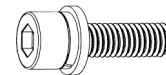
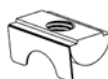

<b>Model</b>	Spiral Wrapping Band	T-Track Cover	Cable Tie
<b>Part Number</b>	CM1	CM2	CM3
<b>Quantity</b>	1.2m	3m	10

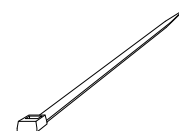
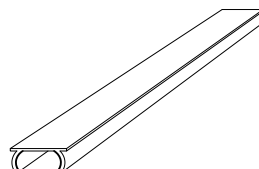
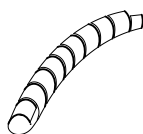

## 1. INSTALLING MOTORS

- Install four **Shaft Couplings** (3) onto the ends of the ball screws (1) to an 11 mm depth, as shown in the diagram.
- Tighten the set screw on each **Shaft Coupling** (3) to secure it to the ball screw (1).
- Install three **Motors** (4) (without brakes) into the X- and Y-axis **Shaft Couplings** (3), with the wire leads (6) facing downward, until they contact the mounting brackets (2).
- Install the **Motor with Brake** (4) into the Z-axis **Shaft Coupling** (3), with the wire leads (6) facing backward, until it contacts the mounting bracket (2).
- Secure the four **Motors** (4) to the mounting brackets (2) using sixteen **M5x16 Galvanized Socket Head Screws** (5) with Lock Washers, fully tightening each screw.
- Tighten the set screws on each **Shaft Coupling** (3) to secure the **Motor** (4) to the ball screw (1).

### Note:

- After installing a motor without brake, avoid moving X-Assembly and Z-Assembly too fast, as rapid motion creates a high push-back voltage that could harm the drivers in the controller.
- After installing a motor with brake, the spindle on the Z-Assembly is locked in place. The brake is released only when powered by the controller.

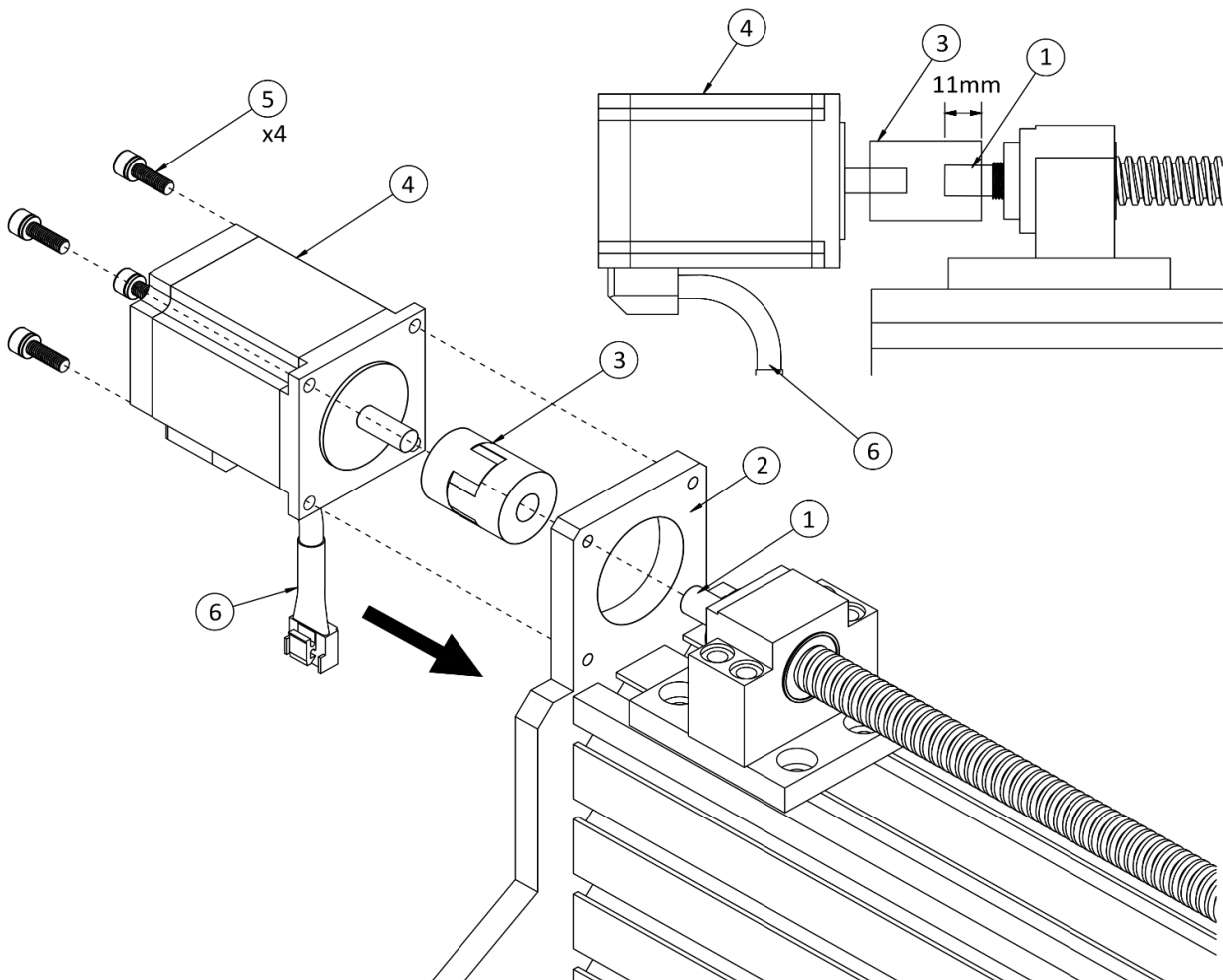

Key No	Part Number	Model	Quantity
3	M4	Shaft Coupling	4
4	M1, M2	Motor	4
5	FG516	M5x16 Galvanized Socket Head Screw with Lock Washer	16

## 2. INSTALLING LIMIT SENSORS

- The limit sensors are pre-installed on the X-Assembly and Z-Assembly at the factory.
- Secure each **Limit Sensor** ① to the ball screw support bracket ③ on both left and right Y assemblies using two M3x20 screws provided with the sensor.
- Adjust the two Y-axis **Limit Sensors** ① to keep the trigger screws ② centered to the front surface with a gap of less than 1 mm.
- Reinstall the two L-shaped dust covers, previously removed, on both Y assemblies.

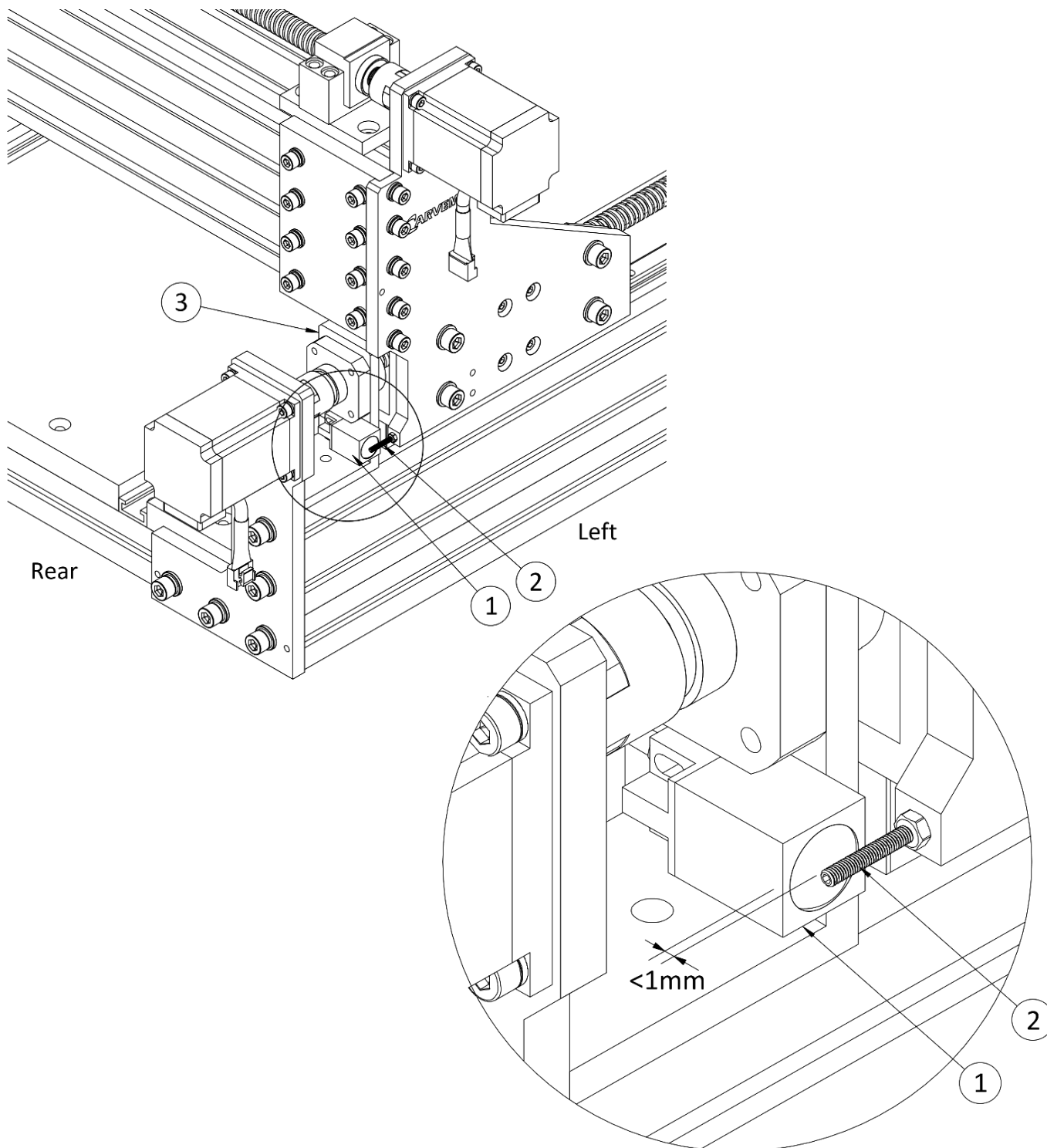

## 3. INSTALLING VFD ENCLOSURE

**NOTE:**

FOR ST494B AND ST4933B MODELS WITHOUT A STAND, THE VFD ENCLOSURE CAN BE MOUNTED ON A WALL OR ANY NEARBY SUPPORT AROUND THE MACHINE, AS LONG AS THE CABLES CAN REACH BOTH THE ELECTRONICS CONTROL BOX AND THE SPINDLE'S MAXIMUM TRAVEL.

- The **VFD Enclosure** (2) mounts on the up-left corner of the stand's left side.
- Orient three **Mounting Brackets** (1) as shown in the diagram.
- Insert three **30M6 Roll-in T-Nuts** (5) into the slots of the stand at the spots indicated by arrows in the diagram.
- Thread two **M6x20 Galvanized Socket Head Screw Sets** (3) with flat Washers, lock washers and nuts into two of the **30M6 Roll-in T-Nuts** (5) in the base's Y-Beam (7).
- Hang the VFD Enclosure by sliding its top two **Mounting Brackets** (1) onto the two screws.
- Secure the left **Mounting Brackets** (1) to the stand's leg (8) by threading one **M6x20 Galvanized Socket Head Screw Sets** (6) into the remaining **30M6 Roll-in T-Nuts** (5).

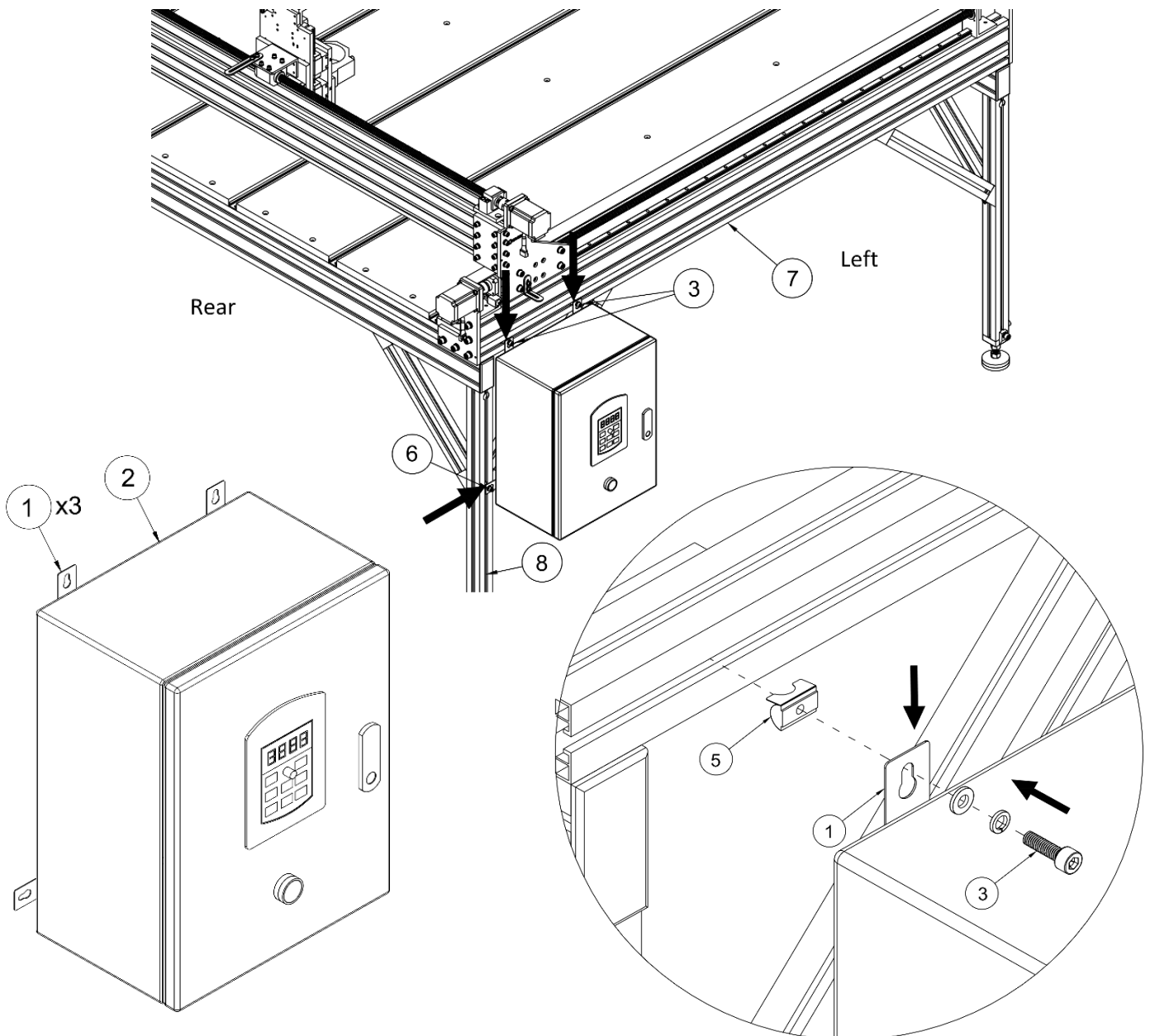

Key No	Part Number	Model	Quantity
1		Mounting Brackets	3
2	VB15, VB22	VFD Enclosure	1
3,6	FG620B	M6x20 Galvanized Socket Head Screw with Lock Washer and Flat Washer	3
4		M6 Nut	3
5	NR36	30M6 Roll-in T-nut	3

## 4. INSTALLING SPINDLE

- The top four threaded holes ① on the Z-Assembly's carriage plate ③ are for **80 mm Spindle Mount ④**, while the lower four ② are for **65 mm Spindle Mount**.
- Attach the **Spindle Mount ④** to the matching holes on the Z-Assembly using four **M6 Screws and Lock washers ⑥** (included with the **Spindle Mount ④**).
- Align the **Spindle Mount ④** flush with the top or bottom edge of the Z-Assembly's carriage plate ③.
- Fully tighten the left two screws ⑥ to secure the **Spindle Mount ④**.
- Slide the **Spindle ⑤** into the **Spindle Mount ④** from the top to the desired position, then tighten the right two screws ⑥ to secure it.
- To access the **Spindle ⑤**, loosen only the right two screws ⑥.

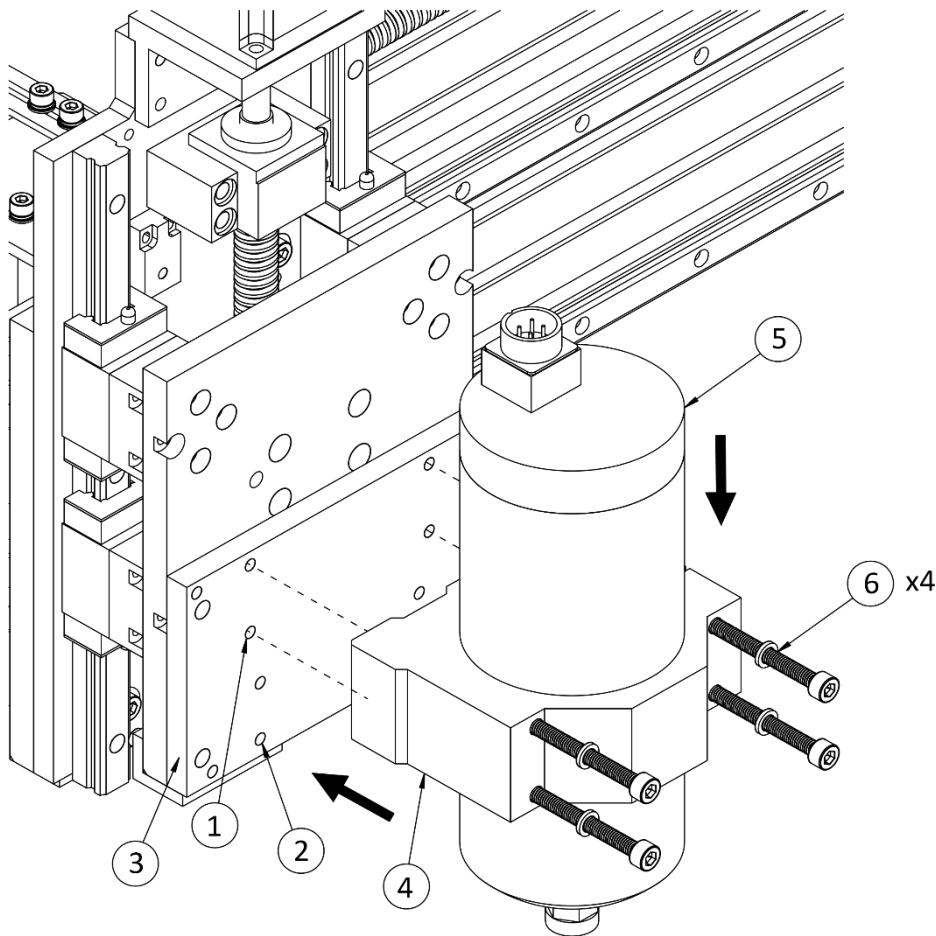

Key No	Part Number	Model	Quantity
4	Z80, Z65	Spindle Mount	1
5	S15	Spindle	1
6		M6 Screw with Lock Washer (Z80)	4

## 5. CABLE WIRING

### ⚠ WARNING:

- DO NOT CONNECT OR DISCONNECT CABLES WHILE THE CONTROLLER IS POWERED ON.
- USE A GROUNDED, 3-PRONG OUTLET FOR THE POWER SUPPLY; UNGROUNDED 2-PRONG OUTLETS ARE PROHIBITED.
- Four Motor cables and four limit sensor cables are color-coded for each axis: red for X axis, blue for Left Y axis (Y), green for right Y axis (A), and yellow for Z axis.
- All connectors are keyed to prevent incorrect connections. Ensure each cable is securely locked before powering on.
- Open all drag chain link caps with a small screwdriver before routing cables.
- Connect cables to the machine components according to the wiring diagram, then route them through the drag chains before connecting to the controller, following the diagrams and tables below.
- Use **Spiral Wrapping Bands** and **Zip Ties** to secure and organize the cables.

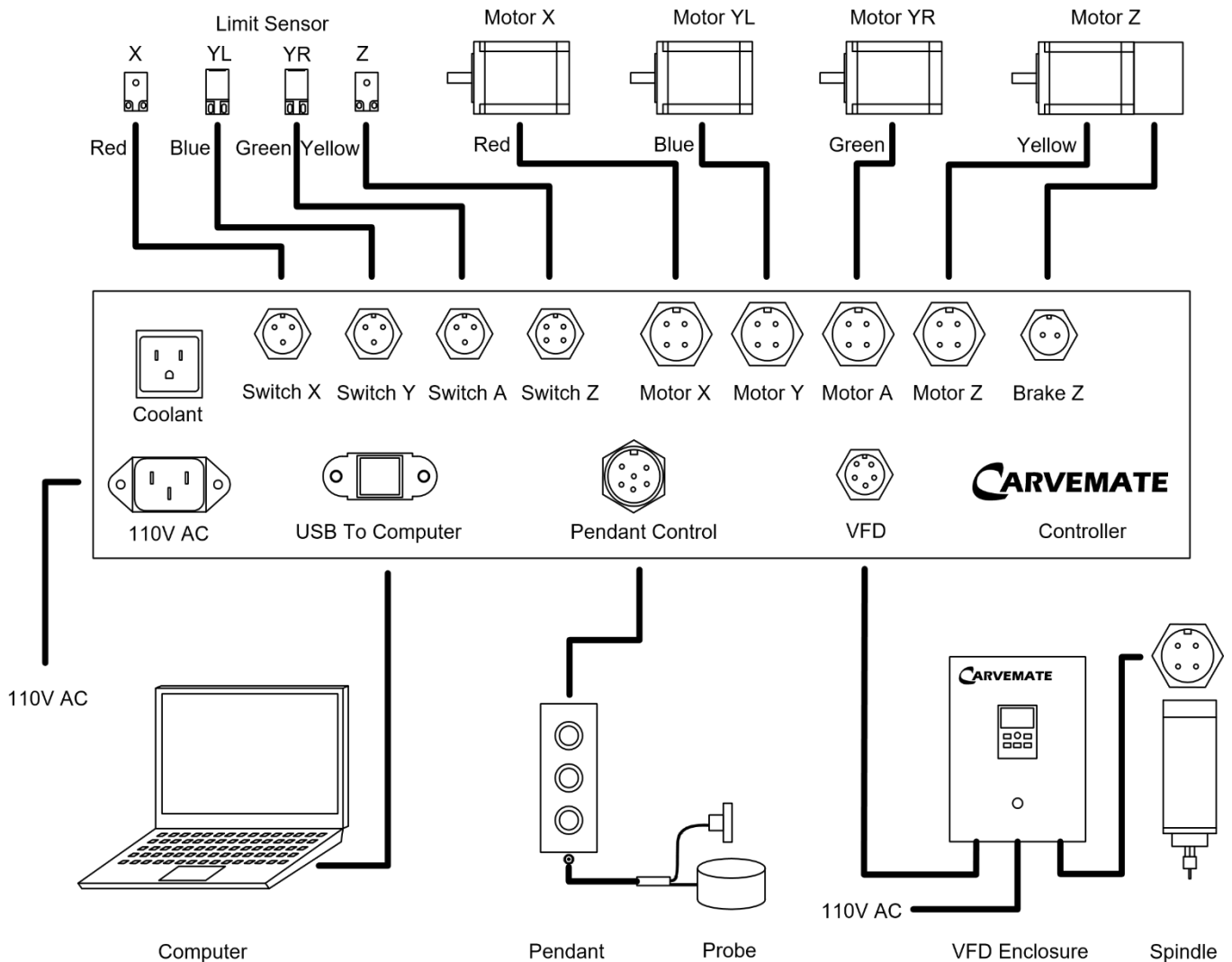

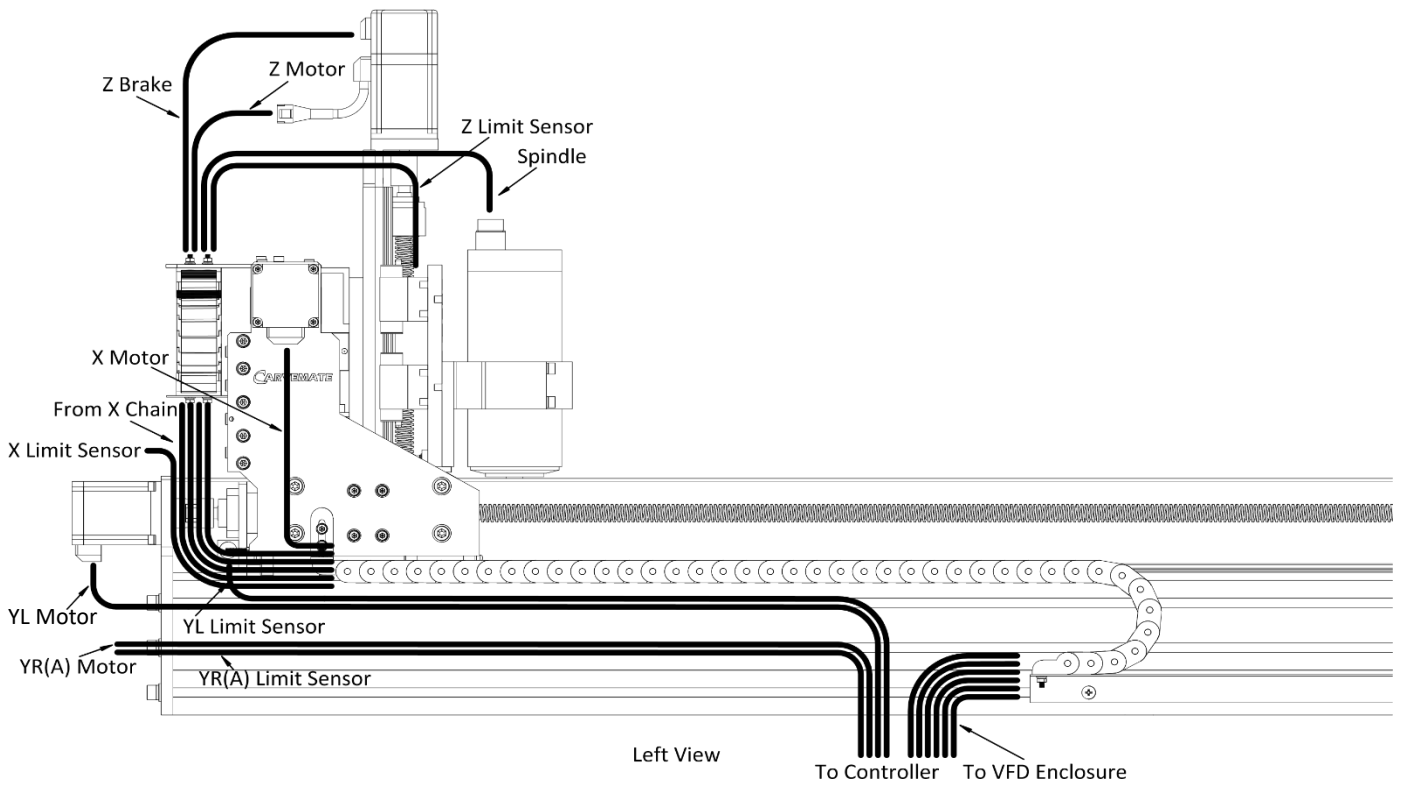
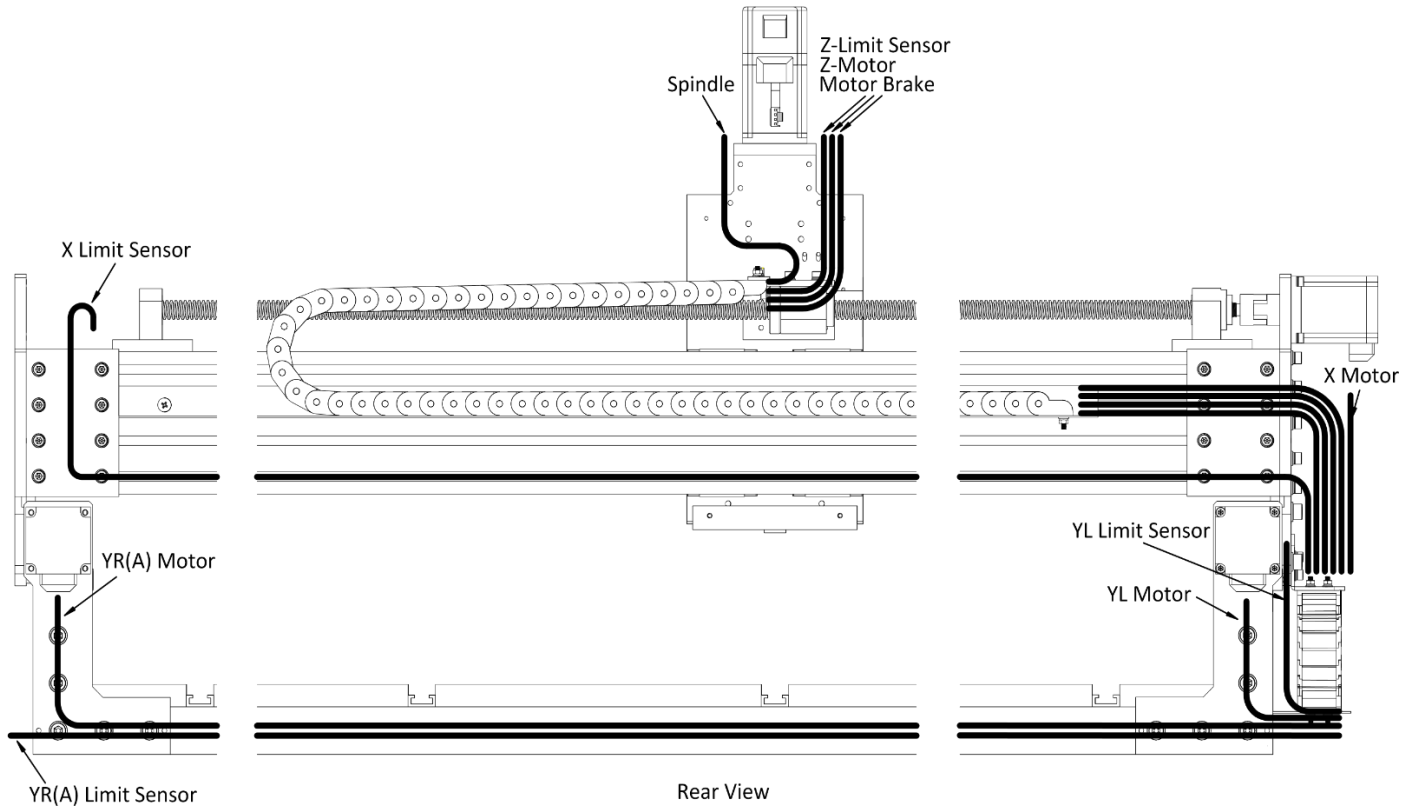

# ELECTRONICS

# ASSEMBLY

Part Number	Cable	Color	From	Route	To
CB8X	X-Motor Cable	Red	X-Motor	Y-Drag Chain	Controller
CB8Y	YL-Motor Cable	Blue	YL-Motor	YL-Beam Slot	Controller
CB8A	YR-Motor Cable	Green	YR-Motor	Rear X-Cross Bar of Base > YL-Beam Slot	Controller
CB8Z	Z-Motor Cable	Yellow	Z-Motor	X-Drag Chain > Y-Drag Chain	Controller
CB9X	X-Sensor Cable	Red	X-Sensor	X-Assembly Slot > Y-Drag Chain	Controller
CB9Y	YL-Sensor Cable	Blue	YL-Sensor	YL-Beam Slot	Controller
CB9A	YR-Sensor Cable	Green	YR-Sensor	Rear X-Cross Bar of Base > YL-Beam Slot	Controller
CB9Z	Z-Sensor Cable	Yellow	Z-Sensor	X-Drag Chain > Y-Drag Chain	Controller
CB10	Z-Brake Cable		Z-Brake	X-Drag Chain > Y-Drag Chain	Controller
	Spindle Cable		Spindle	X-Drag Chain > Y-Drag Chain	VFD Enclosure

Part Number	Cable	From	To
CB5	USB Cable	Controller	Computer
	Power Cord In (Switch Box)	Power Supply	Switch Box
	Power Cord Out (Switch)	Switch Box	Controller
	Power Cord (VFD)	VFD Enclosure	Power Supply
	VFD Control Cable	VFD Enclosure	Controller

- **Secure** the cables in the aluminum extrusion slots using **T-Slot Cover** ①.

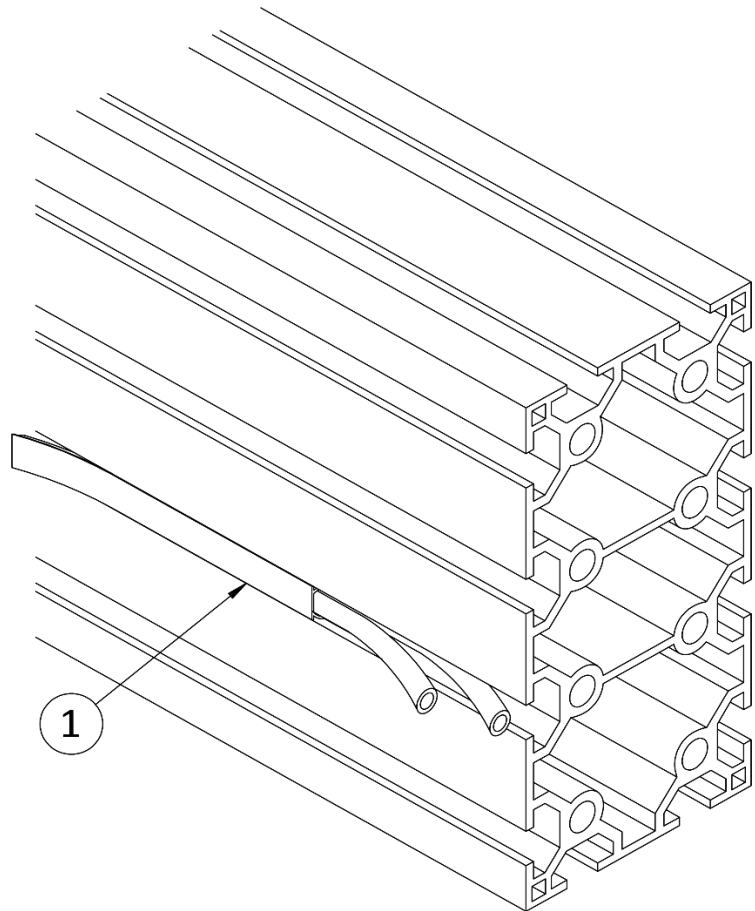

- Reattach the two **L-shaped dust covers** back to the left and right **Y-Assemblies**.

# OPERATION

# COORDINATE SYSTEM

- The CNC machine operates with two coordinate systems: the Machine Coordinate System (**MCS**) and the Work Coordinate System (**WCS**).
- The MCS is the machine's fixed, default coordinate system. Its origin (X0, Y0, Z0) is the home position, located near the X, Y, and Z limit sensors at the top-right-back of the machine. Operators cannot set, reset, or select the MCS. The machine operates entirely in negative coordinate space relative to this origin.
- The WCS defines the workpiece location within the machine's working area. Operators set the WCS origin based on the MCS. These custom settings are referred to as work offsets.

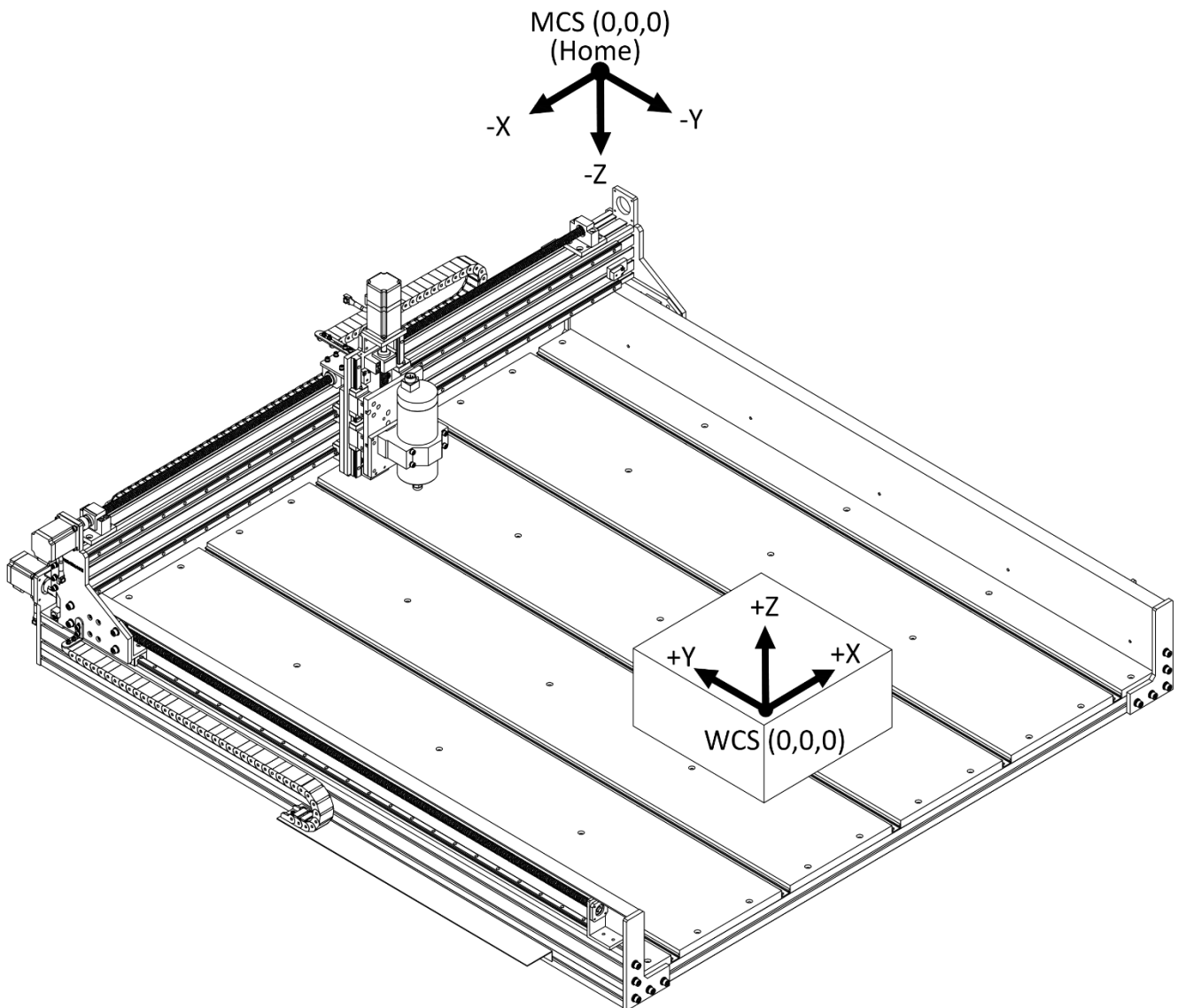

## 1. ADJUSTING LIMIT SENSORS TO SET MACHINE HOME POSITION

- This procedure sets the machine home (X0, Y0, Z0) by adjusting the limit sensor trigger points.
- Sensor LEDs stay on when untriggered and turn off if triggered or malfunctioning.
- The X and Z limit sensors are pre-installed and require no adjustment.
- Remove the spindle from the Z-Assembly.
- Connect the four limit sensors and Z-brake to the controller. Disconnect all other cables, then power on the controller.
- Confirm that each sensor LED is illuminated.
- Gently push the X-Assembly toward the rear of the machine. The **Trip Flag** ② (M3 threaded rod) should trigger the **Y-Limit Sensor** ① before any mechanical contact occurs.
- If the **Limit Sensor** ① is not triggered, adjust it in or out until the **Trip Flag** ② activates it without contact. Secure the sensor.
- To adjust the Y home position, rotate the shaft coupling to move the X-Assembly to the desired position.
- Threading out the **Trip Flag** ② until it just triggers the sensor at new position.
- Slide the X-Assembly back and forth to confirm consistent triggering at the new position.
- Tighten the nut to lock the **Trip Flag** ② in place.
- Always check that the limit sensor triggers correctly if its position has been changed.
- After adjustment, pull the X-Assembly away to ensure the sensors are untriggered. Moving parts must not reach or pass the trigger points when the machine is operating.

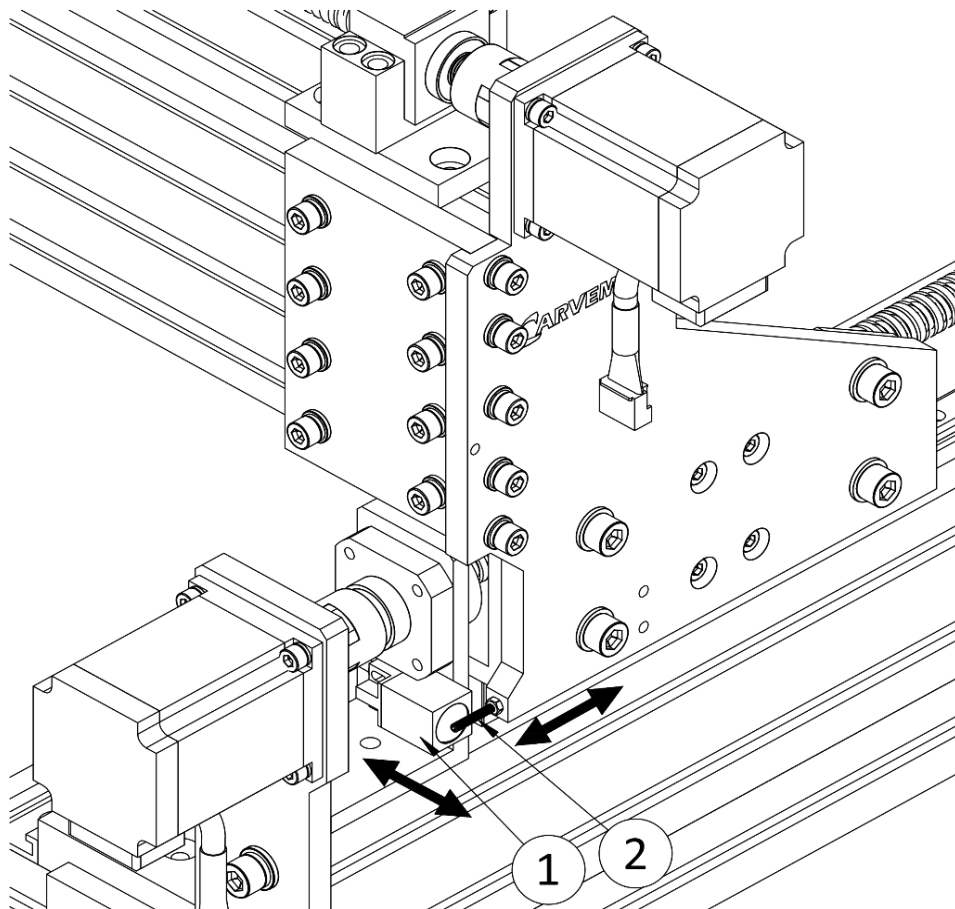

- Relocate the X and Z limit sensors if the X or Z home positions need adjustment.

## 2. MECHANICAL CHECK

- Connect the four limit sensors and Z-brake to the controller. Disconnect all other cables, then power on the controller.
- Gently move the X, Y, Z assemblies back and forth through their full travel range. Movement should feel uniformly firm but smooth, without abnormal friction, vibration, or unusual mechanical noise. If any irregularities are detected, refer to the “Troubleshooting” section.
- Push the X, Y, Z assemblies toward the limit sensors, ensuring the sensors remain untriggered.

## 3. CONTROLLER



Front Panel

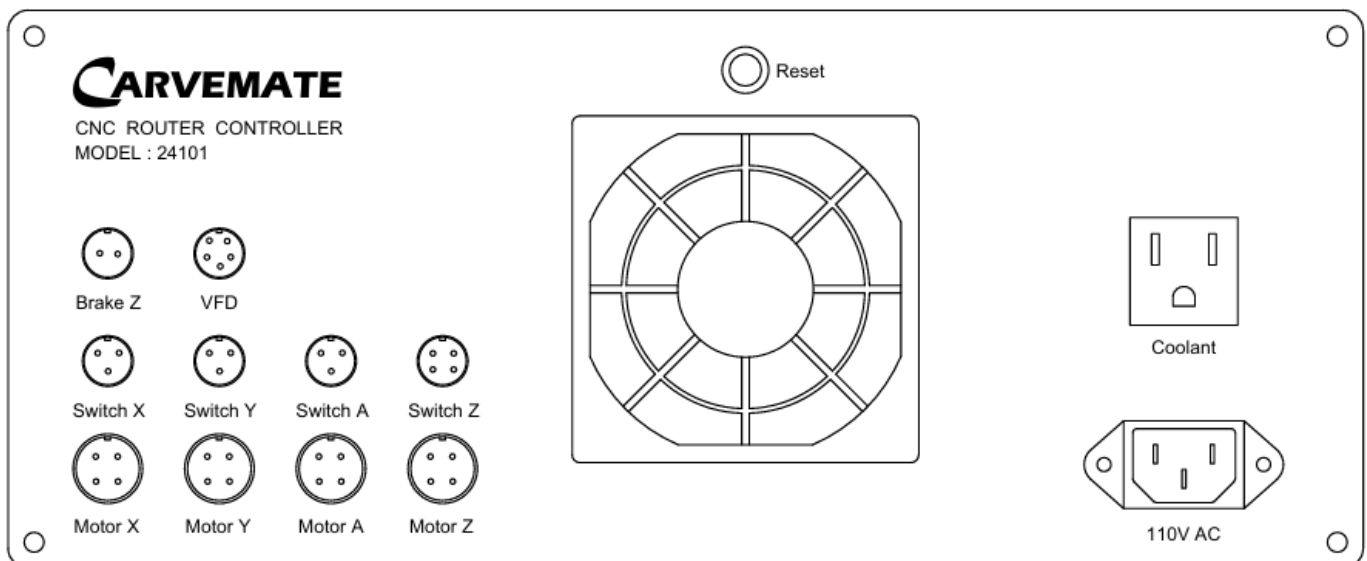

Rear Panel

- The “Reset” button on the rear panel resets the GRBL firmware to recover from errors or restart motion control.
- The “Coolant” socket is activated by the GRBL M08 command and provides a 110 AC 5 A output for the spindle flood coolant pump.

## 4. CONNECTING CONTROLLER TO UGS

- The CNC router's controller runs on GRBL firmware. Universal G-Code Sender (UGS) software, running on a computer, communicates with the controller's GRBL firmware via a USB cable.
- Other third-party GRBL controller software may be used at the user's risk. Improper settings or operations could cause damage to the machine. This manual is based on using UGS for all machine setup and operation instructions.
- Users should refer to external resources for a comprehensive understanding of UGS features. This manual provides only basic instructions.
- UGS software and resources are available at the following link:  
[https://winder.github.io/ugs\\_website/](https://winder.github.io/ugs_website/)  
<https://github.com/winder/universal-g-code-sender/releases>
- UGS is under active development, so it is recommended to install the latest stable version for the best performance. Visit the UGS download page here and select the appropriate version for your operating system:  
[https://winder.github.io/ugs\\_website/download/](https://winder.github.io/ugs_website/download/)
- On Windows, the downloaded file is in .ZIP format. Unzip it, then open the folder "ugsplatform-win", go into the "bin" folder, where you'll find two executable files:  
For Windows 32-bit version, double-click "ugsplatform.exe".  
For Windows 64-bit version, double-click "ugsplatform64.exe".
- To add a desktop shortcut, right-click the executable file, select "Send to" > "Desktop (create shortcut)". This creates a quick-access icon for launching UGS.
- On macOS, download the UGS .dmg installer and save it to your desktop. Open the .dmg file, then drag the UGS icon into the Applications folder. Go to Applications, double-click the UGS icon to start the program. If it fails to launch, ensure that Java is installed. If not, install Java from java.com first, then try again.
- After launching UGS, connect the controller to the computer's USB port with the USB cable.
- In the toolbar at the top of the interface, set the baud rate to 115200, select "GRBL" from the firmware combo box, and choose the correct port from the port box.

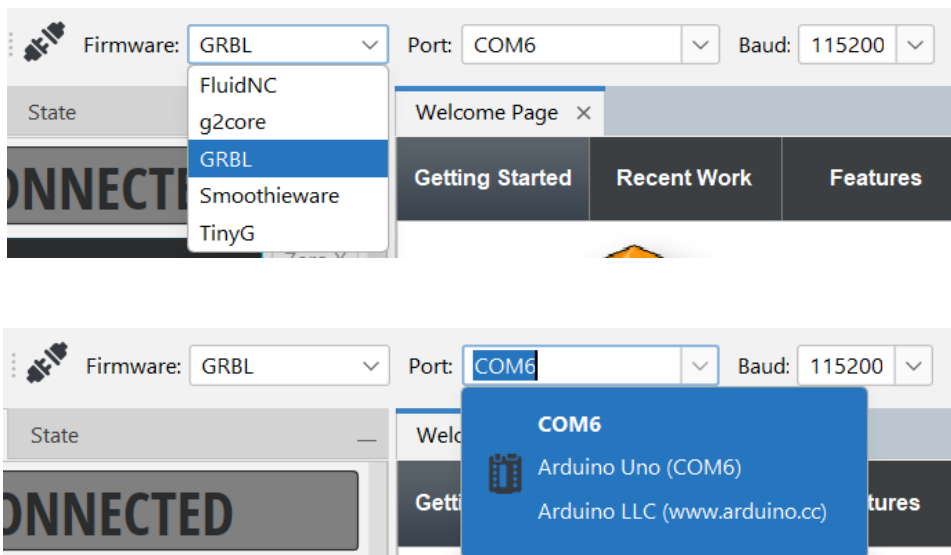

- Click the connect button (the buckle icon). If the status shows "IDLE" or "ALARM", the machine has successfully connected.

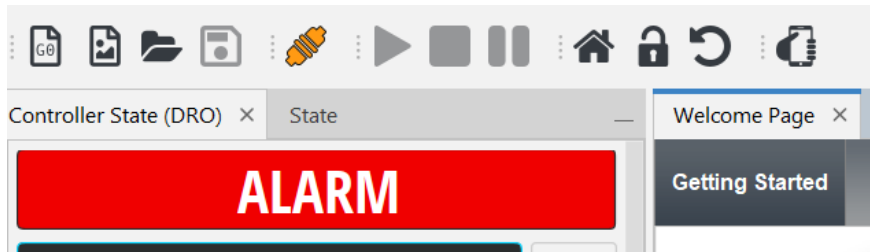

- In the top toolbar, click the “Unlock” button to clear the “ALARM” state. The status should update to “IDLE”, indicating the machine is ready.

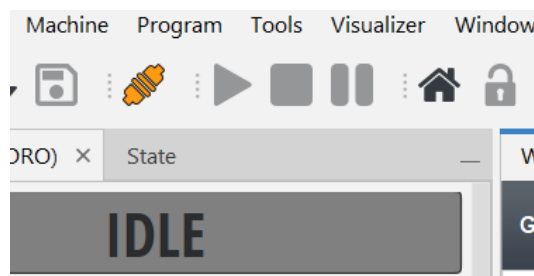

## 5. CONFIGURING GRBL

### ⚠ WARNING:

- **DO NOT CHANGE ANY OF THE SETTINGS LISTED IN THIS SECTION UNLESS YOU FULLY UNDERSTAND WHAT YOU ARE DOING! IMPROPER CONFIGURATION CAN RESULT IN MECHANICAL DAMAGE OR LOSS OF PRECISION.**
- **THIS SECTION PROVIDES ONLY GENERAL INFORMATION AND ACCESS INSTRUCTIONS FOR GRBL SETTINGS. IT IS NOT INTENDED AS A GUIDE FOR MAKING CHANGES.**
- **ALWAYS RUN A HOMING CYCLE AFTER POWER-UP, RECONNECTION, OR SOFTWARE RESET. JOGGING WITHOUT HOMING CAN RESULT IN OVERTRAVEL AND POTENTIAL MACHINE DAMAGE DUE TO UNKNOWN SPINDLE POSITION.**

- To access machine settings, click “Machine” tab in the top menu, then select “Firmware Settings” from the dropdown menu. The configuration windows will open.
- Click “Export” to save a backup of the current settings. Click “Import” To restore settings from a saved file.
- Always backup the settings before making any change.
- Most of settings can also be edited by selecting “Setup Wizard” from “Machine” tab at the top toolbox.

Setting ^	Value	Description
\$0	10	Step pulse time
\$1	25	Step idle delay
\$2	0	Step pulse invert
\$3	1	Step direction invert
\$4	0	Invert step enable pin
\$5	1	Invert limit pins
\$6	0	Invert probe pin
\$10	1	Status report options
\$11	0.010	Junction deviation
\$12	0.002	Arc tolerance
\$13	0	Report in inches

## 6. PRIMARY SOFTWARE OPERATIONS

- The toolbar can be customized by right clicking in the toolbar and selecting “Customize”. From there new actions can be added or removed by dragging them to or from the desired position. The default toolbar layout, from left to right, is as follows:

New G-code File, New Design, Open File, Save File, Connect/Disconnect, Send (Resume), Stop, Pause, Home, Unlock, Soft Reset, Web Based Pendant Control.



- The Digital Readout (Controller State) panel displays the machine’s current status, including work coordinates, machine / spindle speeds and G-Code states.

From top to bottom:

- Current machine state (Idle, Run, Jog, Alarm, etc.),
- Current work coordinates and machine coordinates
- Axis zeroing buttons (X0, Y0, Z0) for setting each current axis position to zero in the WCS.

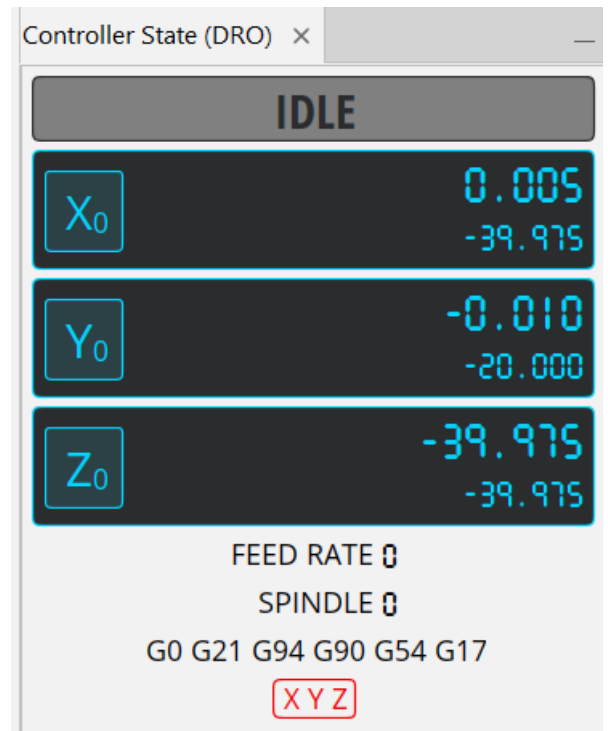

- The “Jog Controller” panel provides manual motion control of the machine.

X-: Left                      X+: Right  
 Y-: Forward                Y+: Backward  
 Z-: Down                    Z+: Up

- If the panel appears grayed out with an “ALARM” status, click the “Unlock button” to clear the alarm. The status should update to “IDLE”, indicating the machine is ready.

- Unit:

Step size: mm or inch,  
 Feed rate: mm per Minute or inch per minute

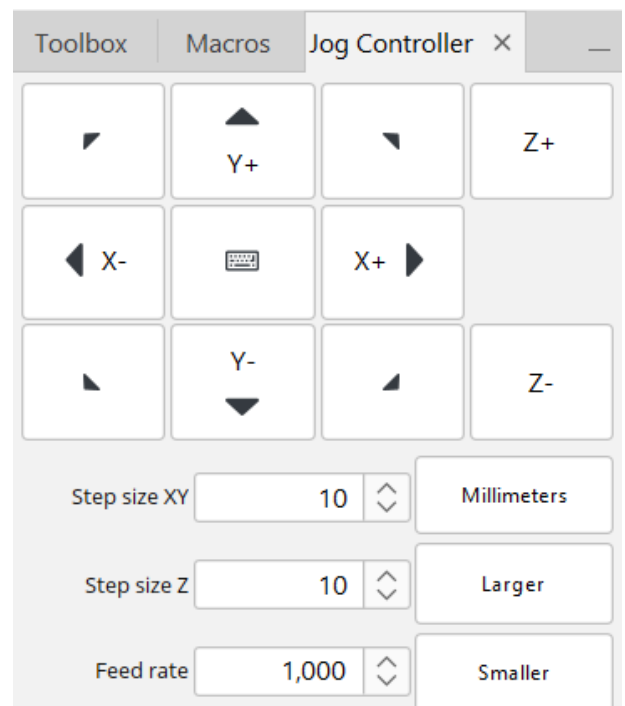

- Reset Zero: Sets the current coordinate (X, Y, Z) in the Machine Coordinate System (MCS) to (0, 0, 0) in the Work Coordinate System (WCS).
- Home Machine: Moves the spindle to the machine's home position (0, 0, 0) (origin of MCS).
- Go to XY Zero: Moves the spindle to (X0, Y0) only in the WCS **without changing the Z-axis height. Ensure the travel path is clear to avoid potential collisions.**
- Return to Zero: Moves the Z-axis to **only 5 mm above Z0** (typically the workpiece surface), then moves the spindle to (X0, Y0) in the WCS. **Ensure the travel path is clear to avoid potential collisions.**

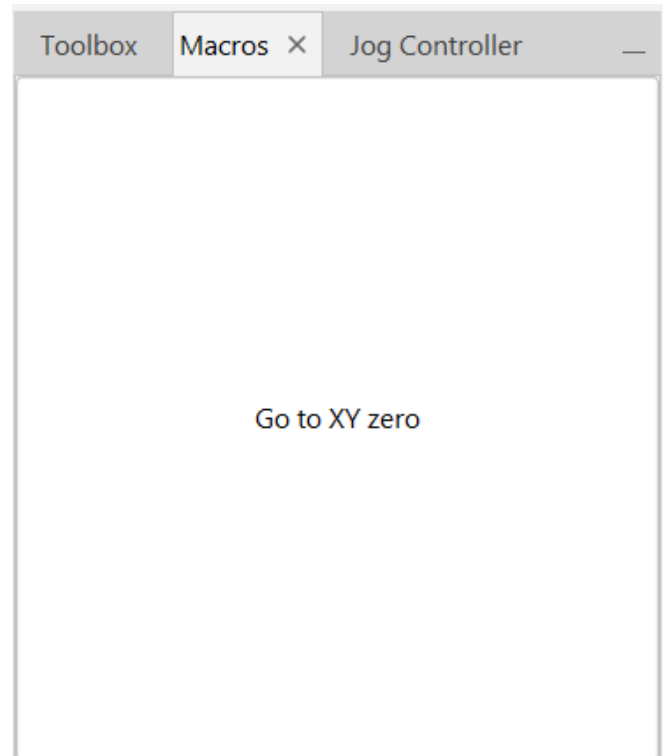
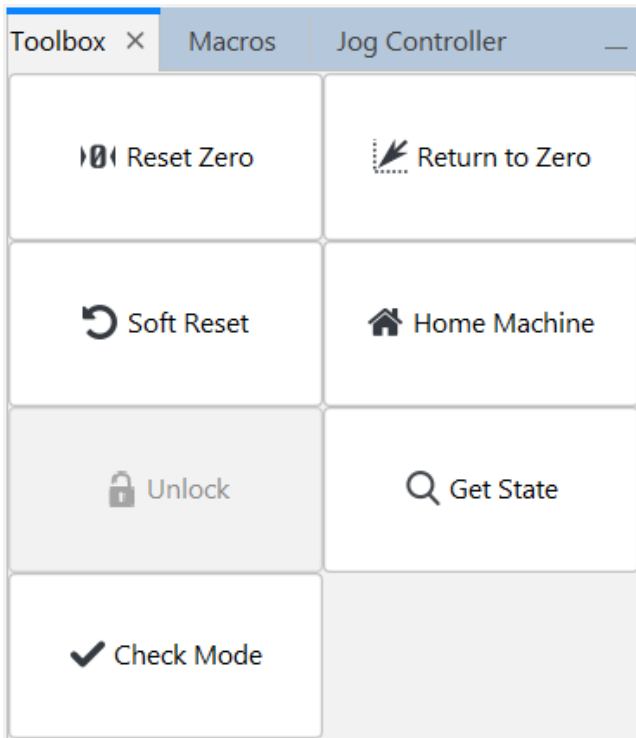

## 7. LIMIT SENSOR CHECK

- In section 1, the limit sensors were adjusted for proper functionality. This section checks whether UGS correctly detects each sensor's live status-triggered or untriggered.
- Select "Setup Wizard" from the "Machine" tab at the top toolbox.
- Click "Next" to reach "5. Limit Switches".
- Ensure both "Enable limit switches" and "Invert limit switches" are checked.
- The X, Y, and Z sensor status blocks should now appear green.
- Using a screwdriver, manually trigger each limit sensor (X, Y, A (YR), Z). The corresponding status block (X, Y, Y and Z, Z) should turn red when triggered. If not, refer to the "Troubleshooting" section.

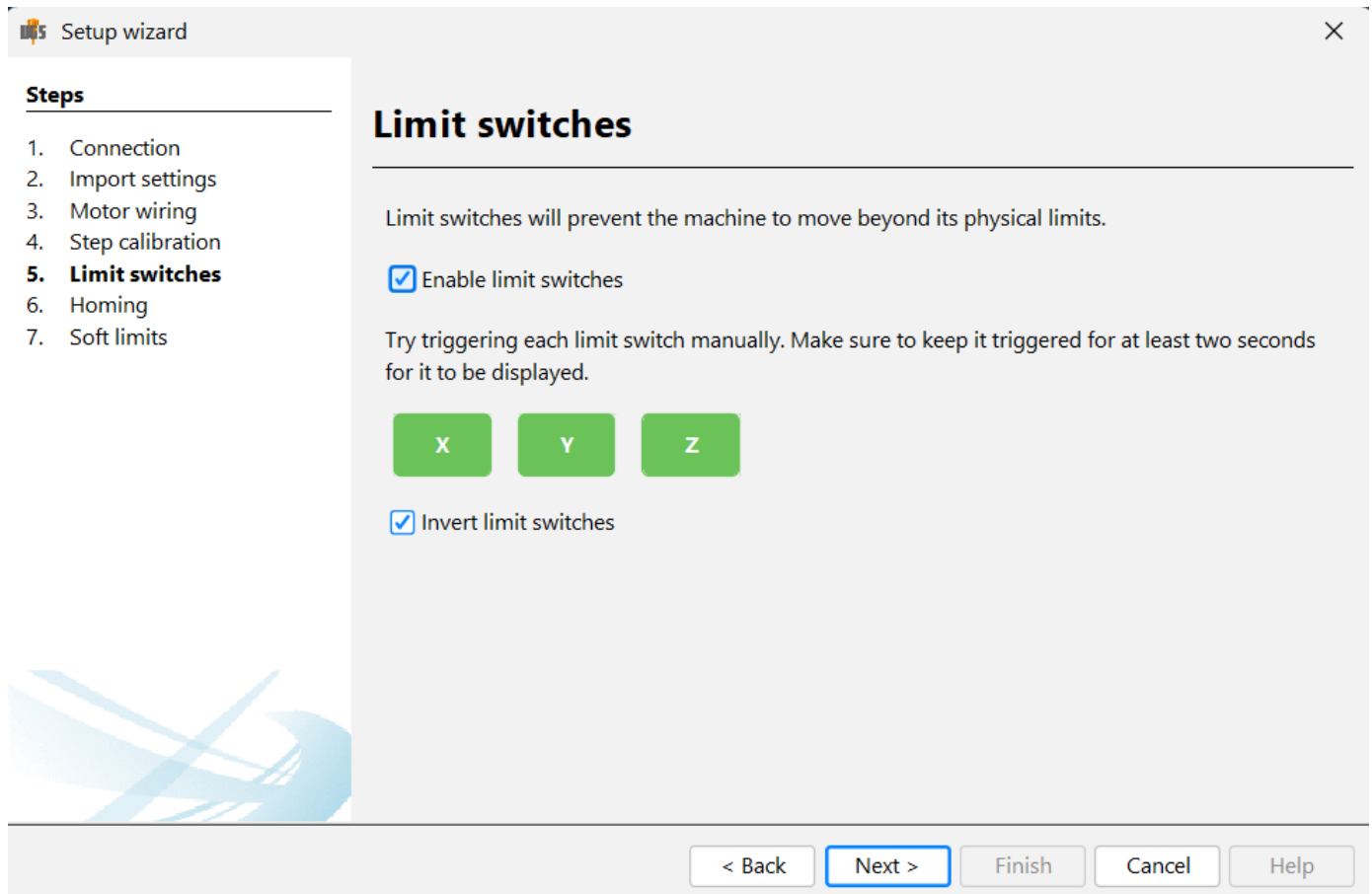

## 8. MOTION AND SPEED CHECK

- To ensure safe motion and accurate calibration, start with a low feed rate and gradually increase to full operating speed.
- Make sure the machine is near the home position and all limit sensors are untriggered. Mark reference points of X, Y, and Z axes for measurement.
- Set the feed rate to 1000 mm/min (or 40 ipm). Set the XY step size to 100 mm (or 5 in) and the Z step size to 20 mm (or 1 in).
- Jog the machine using X-, Y-, and Z- buttons. Confirm the movement direction is as expected (left, forward, down) and the travel distances match step size settings. If not, refer to “Troubleshooting” section.
- Jog the machine back to the start position using X+, Y+, and Z+ buttons.
- Click the “Home” button in the toolbar to home the machine.
- Gradually increase step sizes up to machine travel limits:
  - ST4949: X = 1260 mm, Y = 1260 mm
  - ST4933: X = 1260 mm, Y = 840 mm
  - Z = 132 mm
- Increase feed rate in steps (2000, 4000, 6000, 10000, then maximum speed). Monitor for smooth motion and no abnormal noises at each step:
  - Max XY: 12000 mm/min (472 ipm)
  - Max Z: 8000 mm/min (315 ipm)

## 1. X-AXIS SELF-SQUARING

- The machine is equipped with two independent limit sensors on both Y-Assemblies. During the homing cycle, the X-Assembly automatically squares itself based on the trigger points of these sensors.
- Determine how much the X-Assembly needs to be adjusted to achieve proper squaring using any method you prefer. This manual does not provide detailed instructions.
- Turn off the controller. Manually rotate the ball screw to adjust the right side of the X-Assembly until it is square with the Y-axis.
- Turn on the controller. Adjust the trigger point of the right limit sensor as described in the “ADJUSTING LIMIT SENSORS TO SET MACHINE HOME POSITION” section.
- Run a homing cycle. If the X-axis is still misaligned, repeat the adjustment steps.

## 2. Z-AXIS TRAMMING

- Tramming is the process of squaring the Z-axis **Spindle** ② to ensure it's perpendicular to the work surface in both the X and Y directions.
- Jog the Z-Assembly to the center of the work surface.
- This section describes a spindle body-based method for squaring the spindle. Other methods, such as directly measuring the cutting bit for higher accuracy, are not detailed here.
- Mount the **Spindle** ② into the **Spindle Mount** ③. Slide it down until the **Mount** ③ securely grips the top of the metal body.
- Jog the Z-Assembly up so an **Engineer's Square** ① can reach the **Spindle** ②.
- Loosen the four **M6 Screws** ⑧ to allow the **Spindle Plate** ④ to move freely.
- Place the **Engineer's Square** ① on the work surface against the left side of the **Spindle** ② (X direction), and check if the **Spindle** ② stands square with the work surface.
- Adjust one of the two **Set Screws** ⑦ at the bottom of the two **L-Shaped Brackets** ⑥ to square the **Spindle** ② in X direction. Only adjust one **Set Screw** ⑦ to ensure at least one side of the **Spindle Plate** ④ stays on the **L-Shaped Bracket** ⑥.

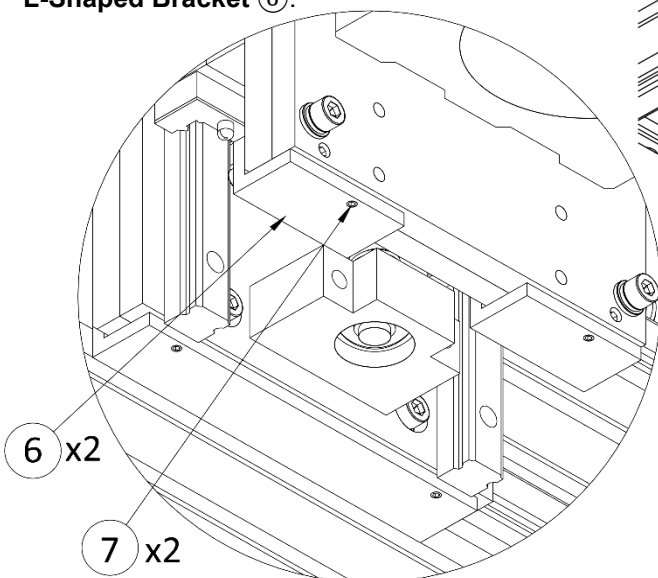
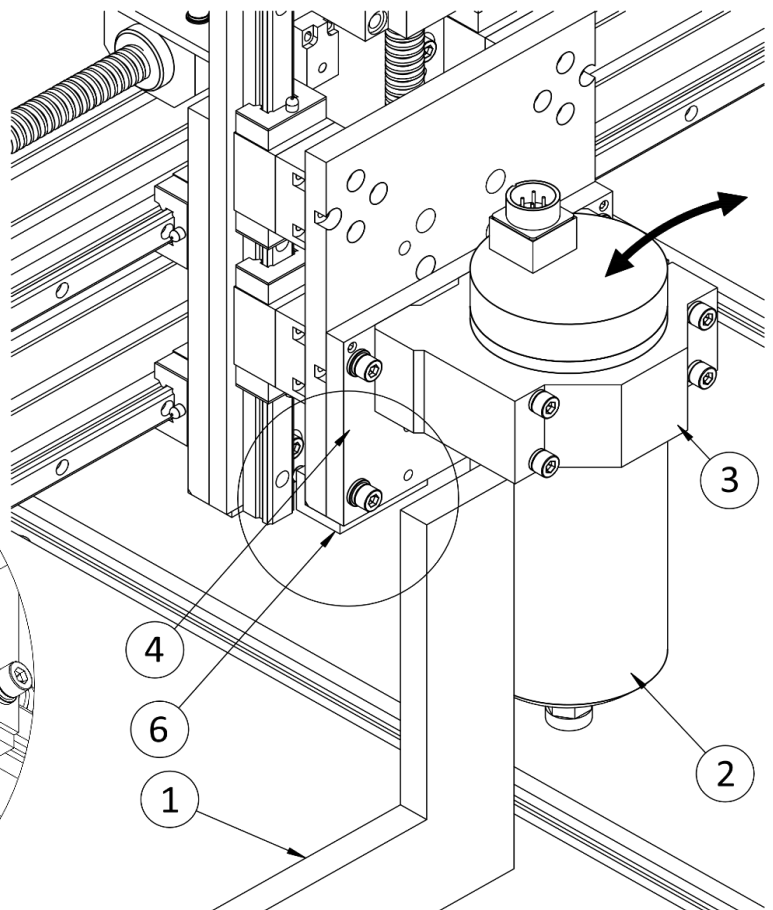

# OPERATION

# ADJUSTMENT

- Place the **Engineer's Square** ① on the work surface against the front side of the **Spindle** ② (Y direction), and check if the **Spindle** ② stands square with the work surface.
- To square the **Spindle** ② in the Y direction, turn either the top two **Set Screws** ⑨ or the bottom two clockwise the same amount to push the **Spindle Plate's** ④ top or bottom away from the **Carriage Plate** ⑤.
- Shim the gap between the **Spindle Plate's** ④ and the **Carriage Plate** ⑤, then fully tighten the four **M6 Screws** ⑧.

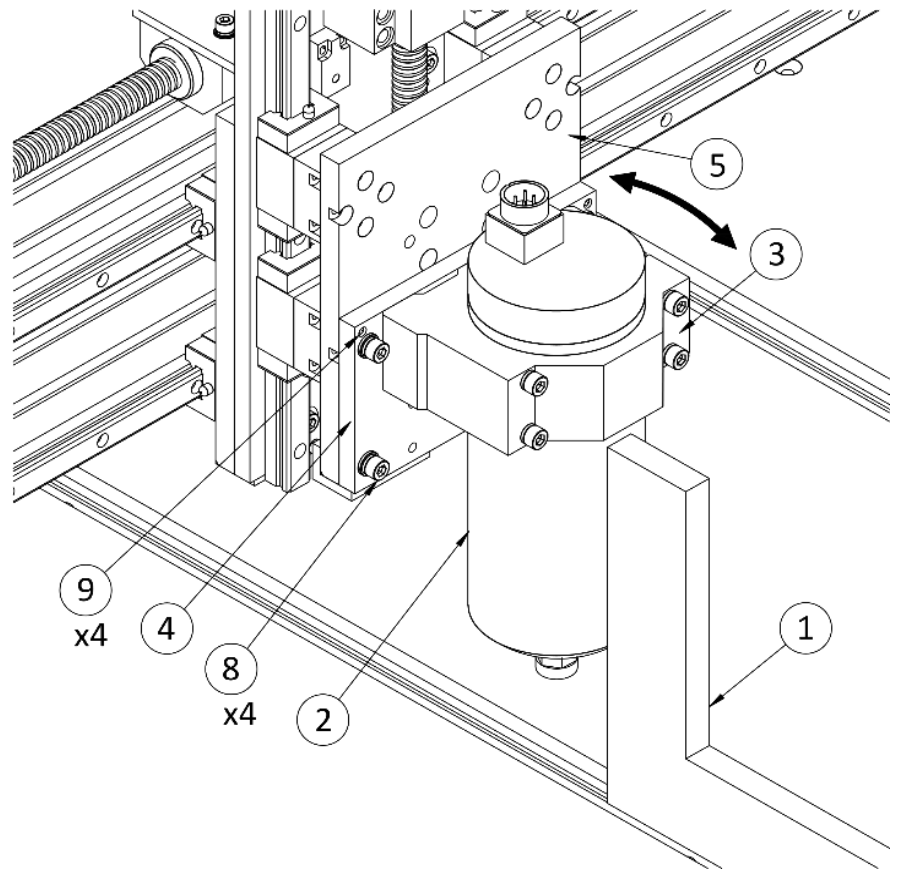

## 3. PENDANT BOX

- The pendant box features three buttons – **Resume**, **Abort**, and **Pause** – for convenient control near the workpiece. These buttons have the same functions as those in the UGS top toolbar.

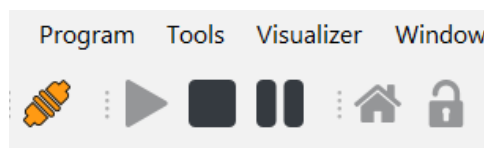

## 4. Z AXIS PROBING

- The touch probe measures the workpiece's Z-axis origin automatically.
- Install the cutting bit into the spindle.
- Jog the spindle above the workpiece.
- Plug the probe into the pendant box.
- Place the probe base on the surface of the workpiece, directly under the cutting bit.
- Lower the Z axis until the end mill is less than 10 mm above the probe base.
- Attach the magnet end to the cutting bit.

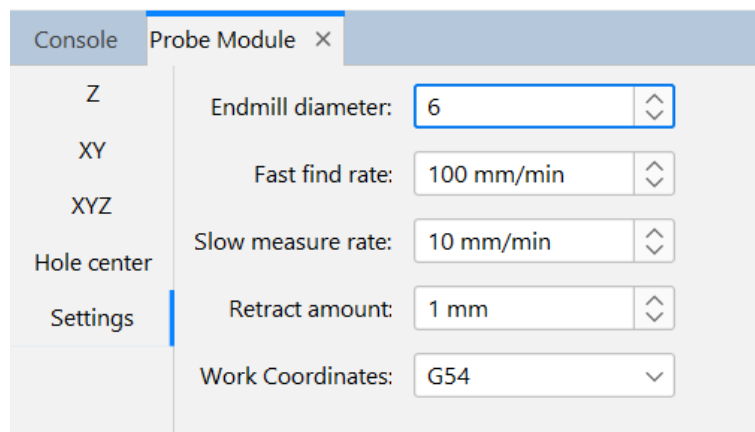

# OPERATION

# ADJUSTMENT

- In UGS, click “Probe Module” tab and go to “Settings”.
- Set the following:
  - Fast Find Rate: 100 mm/min
  - Slow measure rate: 10 mm/min
  - Retract amount: 1 mm
- Under “Z” tab:
  - Touch plate thickness: 18.9 mm
  - Probe distance/Direction: -10 mm
- Click “Probe and Zero Z” button to start Z Probe process.
- **It is strongly recommended to run a virtual probing first to confirm probe connectivity and prevent damage to the cutting bit.**
- Jog to the desired origin of the workpiece.
- Press “X0” and “Y0” in the Digital Readout panel to set the X, Y origin in the WCS.

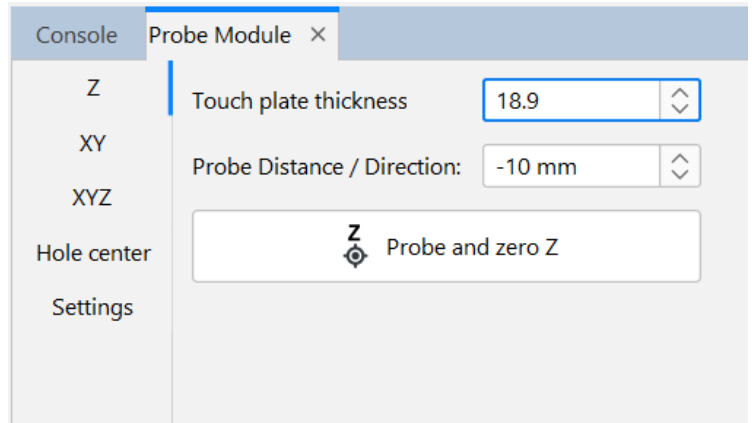

## **⚠ WARNING:**

- **DO NOT MODIFY VFD PARAMETERS UNLESS YOU FULLY UNDERSTAND THEIR FUNCTION. INCORRECT CONFIGURATION MAY DAMAGE THE SPINDLE OR VFD.**
- **NEVER OPERATE THE SPINDLE WITHOUT PROPERLY SECURING THE COLLET NUT AND CUTTING BIT. UNSECURED COMPONENTS CAN CAUSE SERIOUS INJURY.**
- **THE VFD INCLUDED WITH THIS MACHINE IS PRE-CONFIGURED TO OPERATE WITH THE SPECIFIED SPINDLE. RECONFIGURATION IS NECESSARY TO USE A DIFFERENT SPINDLE. SEE THE VFD MANUAL.**
- **THE INCLUDED SPINDLE IS A 24,000 RPM HIGH-SPEED MODEL. IT CANNOT OPERATE EFFECTIVELY BELOW 2,000 RPM DUE TO INSUFFICIENT TORQUE.**

- The spindle RPM (Revolutions Per Minute) is equal to sixty times the pulse frequency displayed on the VFD.
- The VFD is controlled by UGS software. Manual spindle control on the VFD using keypad and dial is disabled.
- Always perform a full spindle run-in before placing a cold spindle into operation. This ensures optimal performance and maximizes spindle lifespan.

- **Spindle Break-In:**

Perform this procedure if the spindle is brand new, has been idle for more than two weeks, or if the bearings have been replaced. During the process, ensure the spindle temperature remains low enough to comfortably touch with your bare hand.

Stage 1: 2500 RPM, 20s run, 60s stop, 5 times

Stage 2: 5000 RPM, 20s run, 60s stop, 5 times

Stage 3: 8000 RPM, 20s run, 60s stop, 5 times

Stage 4: 12000 RPM, 20s run, 120s stop, 5 times

Stage 5: 18000 RPM, 20s run, 120s stop, 5 times

Stage 6: 24000 RPM, 20s run, 120s stop, 5 times

Stage 7: 24000 RPM, 30s run, 120s stop, 10 times

Stage 8: 24000 RPM, 60s run, 60s stop, 10 times

Total time: 100 minutes.

- **Spindle Warm-Up:**

Run this procedure prior to spindle operation if the spindle has been unused for more than two hours.

%

M3 S2000

G4 P180 ; 3 minutes at 2000 RPM

M3 S4000

G4 P180 ; 3 minutes at 4000 RPM

M3 S6000

G4 P180 ; 3 minutes at 6000 RPM

M3 S8000

G4 P180 ; 3 minutes at 8000 RPM

M3 S12000

G4 P180 ; 3 minutes at 12000 RPM

M3 S18000

G4 P180 ; 3 minutes at 18000 RPM

M3 S24000

G4 P180 ; 3 minutes at 24000 RPM

M5

M30

%

# TROUBLESHOOTING

CATEGORY	PROBLEM	CAUSE	SOLUTION
Limit Sensor	LED not lit	<ul style="list-style-type: none"> <li>• Sensor is triggered.</li> <li>• Cable connection issues</li> <li>• The sensor failure</li> </ul>	<ul style="list-style-type: none"> <li>• Move the trip flag away</li> <li>• Fix or replace cable or connectors</li> <li>• Replace the sensor</li> </ul>
	LED stays on	<ul style="list-style-type: none"> <li>• Sensor too far from or not aligned with trip flag</li> </ul>	<ul style="list-style-type: none"> <li>• Reposition the sensor</li> </ul>
	UGS Setup Wizard does not show triggered state	<ul style="list-style-type: none"> <li>• Cable connection issue</li> </ul>	<ul style="list-style-type: none"> <li>• Fix or replace cable or connectors</li> </ul>
Motion	No movement	<ul style="list-style-type: none"> <li>• Cable connection issue</li> <li>• Loose shaft coupling</li> </ul>	<ul style="list-style-type: none"> <li>• Fix or replace cable or connectors</li> <li>• Tighten coupling set screws</li> </ul>
	Z-axis motor hums but doesn't move	<ul style="list-style-type: none"> <li>• Z-brake not released</li> </ul>	<ul style="list-style-type: none"> <li>• Check Z-brake and its cable connection</li> </ul>
	X-assembly hard to slide on Y-axis	<ul style="list-style-type: none"> <li>• X-assembly misaligned</li> </ul>	<ul style="list-style-type: none"> <li>• Square the x-assembly</li> </ul>
	Incorrect jog direction or distance	<ul style="list-style-type: none"> <li>• Incorrect GRBL settings</li> </ul>	<ul style="list-style-type: none"> <li>• Review and correct settings in UGS Setup Wizard</li> </ul>
	Abnormal noise during jogging	<ul style="list-style-type: none"> <li>• Loose or misaligned mechanical parts</li> </ul>	<ul style="list-style-type: none"> <li>• Inspect shaft couplings, ball screw nuts, and linear guides</li> </ul>
	Axis stall during motion	<ul style="list-style-type: none"> <li>• Dust on ball screws or linear rails</li> <li>• Lack of lubrication</li> <li>• speed too high, overloaded</li> </ul>	<ul style="list-style-type: none"> <li>• Clean ball screws and linear rails</li> <li>• Apply grease on ball screws and linear rails</li> <li>• Reduce travel speed</li> </ul>
	UGS stop randomly / limit switch or USB Alert	<ul style="list-style-type: none"> <li>• electromagnetic interference (EMI)</li> </ul>	<ul style="list-style-type: none"> <li>• Check the grounding</li> <li>• Check cable connection</li> <li>• Power the control box from separate outlet on different circuit</li> </ul>
Control Box	Power switch LED on, but no power in	<ul style="list-style-type: none"> <li>• Blown fuse</li> </ul>	<ul style="list-style-type: none"> <li>• Replace the fuse inside the controller</li> </ul>
Probe	Probing won't stop	<ul style="list-style-type: none"> <li>• Connection issue</li> </ul>	<ul style="list-style-type: none"> <li>• Check pendant box and cable connections</li> </ul>
VFD	No power	<ul style="list-style-type: none"> <li>• Blown fuse</li> </ul>	<ul style="list-style-type: none"> <li>• Replace the fuse inside the VFD enclosure</li> </ul>
	Spindle not spinning	<ul style="list-style-type: none"> <li>• Connection issue</li> <li>• Incorrect VFD settings</li> </ul>	<ul style="list-style-type: none"> <li>• Check cable and connector</li> <li>• Review and correct VFD settings</li> </ul>
Software	UGS not responsive	<ul style="list-style-type: none"> <li>• Software crash or disconnect</li> </ul>	<ul style="list-style-type: none"> <li>• Reconnect or reset the controller</li> </ul>



